



MIAMI-DADE COUNTY
BUILDING CODE COMPLIANCE OFFICE (BCCO)
PRODUCT CONTROL DIVISION

MIAMI-DADE COUNTY, FLORIDA
METRO-DADE FLAGLER BUILDING
140 WEST FLAGLER STREET, SUITE 1603
MIAMI, FLORIDA 33130-1563
(305) 375-2901 FAX (305) 372-6339

NOTICE OF ACCEPTANCE (NOA)

www.miamidade.gov/buildingcode

West Tampa Glass Company
2705 North 35th Street
Tampa, FL 33605

SCOPE:

This NOA is being issued under the applicable rules and regulations governing the use of construction materials. The documentation submitted has been reviewed by Miami-Dade County Product Control Division and accepted by the Board of Rules and Appeals (BORA) to be used in Miami Dade County and other areas where allowed by the Authority Having Jurisdiction (AHJ).

This NOA shall not be valid after the expiration date stated below. The Miami-Dade County Product Control Division (In Miami Dade County) and/or the AHJ (in areas other than Miami Dade County) reserve the right to have this product or material tested for quality assurance purposes. If this product or material fails to perform in the accepted manner, the manufacturer will incur the expense of such testing and the AHJ may immediately revoke, modify, or suspend the use of such product or material within their jurisdiction. BORA reserves the right to revoke this acceptance, if it is determined by Miami-Dade County Product Control Division that this product or material fails to meet the requirements of the applicable building code. This product is approved as described herein, and has been designed to comply with the Florida Building Code, including the High Velocity Hurricane Zone.

DESCRIPTION: Series "WTG-700" Aluminum Curtain Wall System – S.M.I.

APPROVAL DOCUMENT: Drawing No. **S-4089**, titled "West Tampa Glass – Series WTG-700", sheets 1 through 18 of 18, dated 07/01/09 with revision #2 dated 07/20/10, prepared by RW Building Consultant, signed and sealed by Ryan J. King, P.E., bearing the Miami-Dade County Product Control Approval stamp with the Notice of Acceptance number and approval date by the Miami-Dade County Product Control Division.

MISSILE IMPACT RATING: Small Missile Impact Resistant

LABELING: Each unit shall bear a permanent label with the manufacturer's name or logo, city, state and following statement: "Miami-Dade County Product Control Approved", unless otherwise noted herein.

RENEWAL of this NOA shall be considered after a renewal application has been filed and there has been no change in the applicable building code negatively affecting the performance of this product.

TERMINATION of this NOA will occur after the expiration date or if there has been a revision or change in the materials, use, and/or manufacture of the product or process. Misuse of this NOA as an endorsement of any product, for sales, advertising or any other purposes shall automatically terminate this NOA. Failure to comply with any section of this NOA shall be cause for termination and removal of NOA.

ADVERTISEMENT: The NOA number preceded by the words Miami-Dade County, Florida, and followed by the expiration date may be displayed in advertising literature. If any portion of the NOA is displayed, then it shall be done in its entirety.

INSPECTION: A copy of this entire NOA shall be provided to the user by the manufacturer or its distributors and shall be available for inspection at the job site at the request of the Building Official.

This NOA consists of this page 1 and evidence pages E-1 and E-2, as well as approval document mentioned above.

The submitted documentation was reviewed by **Manuel Perez, P.E.**



NOA No. 09-1202.03
Expiration Date: October 06, 2015
Approval Date: October 06, 2010

NOTICE OF ACCEPTANCE: EVIDENCE SUBMITTED

A. DRAWINGS

1. Manufacturer's die drawings and sections.
2. Drawing No **S-4089**, Sheets 1 through 18 of 18, titled "West Tampa Glass - Series WTG-700", dated 07/01/09 with revision #2 dated 07/20/10, prepared by RW Building Consultants, Inc., signed and sealed by Ryan J. King, P.E.

B. TESTS

1. Test reports on:
 - 1) Air Infiltration Test, per FBC, TAS 202-94
 - 2) Uniform Static Air Pressure Test, Loading per FBC TAS 202-94
 - 3) Water Resistance Test, per FBC, TAS 202-94
 - 4) Small Missile Impact Test per FBC, TAS 201-94
 - 5) Large Missile Impact Test per FBC, TAS 201-94
 - 6) Cyclic Wind Pressure Loading per FBC, TAS 203-94along with marked-up drawings and installation diagram of WTG-500 and WTG-700 aluminum curtain wall systems, Series **WTG-500** specimens: #1, 2, 3, **4, 5**, and **6** and Series **WTG-700** specimens: 1, 3, 6, 7, 9, 11, 15, 17, 19, 21, 23, 23A, 25, 27, 32, **2, 4, 5, 8, 10, 12, 16, 18, 22, 24A, 26, 28, 33**, prepared by Testing Evaluation Laboratories, Inc. Test Report No. **TEL-08-01490001**, dated 01/02/08, signed and sealed by Wendell W. Haney, P.E.
2. Test reports on:
 - 1) Air Infiltration Test, per FBC, TAS 202-94
 - 2) Uniform Static Air Pressure Test, Loading per FBC TAS 202-94
 - 3) Water Resistance Test, per FBC, TAS 202-94
 - 4) Small Missile Impact Test per FBC, TAS 201-94
 - 5) Large Missile Impact Test per FBC, TAS 201-94
 - 6) Cyclic Wind Pressure Loading per FBC, TAS 203-94along with marked-up drawings and installation diagram of WTG-500 and WTG-700 aluminum curtain wall systems, Series **WTG-500** specimens: #40 and 42 and Series **WTG-700** specimens: #36, 37, 39, **36a, 37a, 38, 39a, 41 and 43**, prepared by Testing Evaluation Laboratories, Inc. Test Report No. **TEL-01490139**, dated 08/26/09, signed and sealed by Lyndon F. Schmidt, P.E.
3. Test reports on:
 - 1) Air Infiltration Test, per FBC, TAS 202-94
 - 2) Uniform Static Air Pressure Test, Loading per FBC TAS 202-94
 - 3) Water Resistance Test, per FBC, TAS 202-94along with marked-up drawings and installation diagram of an WTG-700 twin span aluminum curtain wall system, Series **WTG-700** specimen **#30A**, prepared by Hurricane Test Laboratory, LLC, Test Report No. **HTL-0519-0802-08**, dated 08/26/08 to 09/03/09, signed and sealed by Vinu J. Abraham, P.E.

Manuel Perez, H.E.
Product Control Examiner
NOA No. 09-1262.03
Expiration Date: October 06, 2015
Approval Date: October 06, 2010

West Tampa Glass Company

NOTICE OF ACCEPTANCE: EVIDENCE SUBMITTED

B. TESTS (CONTINUED)

4. Test reports on: 1) Air Infiltration Test, per FBC, TAS 202-94
2) Uniform Static Air Pressure Test, Loading per FBC TAS 202-94
3) Water Resistance Test, per FBC, TAS 202-94
4) Small Missile Impact Test per FBC, TAS 201-94
5) Cyclic Wind Pressure Loading per FBC, TAS 203-94
along with marked-up drawings and installation diagram of an WTG-700 twin span aluminum curtain wall system, Series **WTG-700** specimen #29, prepared by Hurricane Test Laboratory, LLC, Test Report No. **HTL-0519-0802-08**, dated 08/04/08 to 08/12/09, signed and sealed by Vinu J. Abraham, P.E.

C. CALCULATIONS

1. Anchor verification calculations and structural analysis, complying with FBC-2007, prepared by RW Building Consultants, Inc., dated 08/01/09 and 08/08/10, signed and sealed by Ryan J. King, P.E.
Complies with ASTM E1300-04

D. QUALITY ASSURANCE

1. Miami Dade Building Code Compliance Office (BCCO).

E. MATERIAL CERTIFICATIONS

1. Notice of Acceptance No. **07-1116.04** issued to E.I. DuPont DeNemours & Co., Inc. for their "**DuPont Sentry Glass® Plus**" dated 01/03/08, expiring on 01/14/12.
2. Notice of Acceptance No. **06-0216.06** issued to **Solutia, Inc.** for their "**Saflex III G Clear or colored Interlayer**" dated 05/04/06, expiring on 05/21/11.

F. STATEMENTS

1. Statement letter of conformance and no financial interest, dated September 7, 2010, signed and sealed by Ryan J. King, P.E.
2. Laboratory compliance letter for Test Report N o. **HTL-0519-0802-08, specimen #30A**, issued by Hurricane Test Laboratory, Inc., dated April 28, 2009, signed and sealed by Vinu J. Abraham, P.E.
3. Laboratory compliance letter for Test Report N o. **HTL-0519-0802-08, specimen #29**, issued by Hurricane Test Laboratory, Inc., dated May 10, 2010, signed and sealed by Vinu J. Abraham, P.E.

G. OTHERS

1. None.



Manuel Perez, P.E.
Product Control Examiner
NOA No. 09-1202.03

Expiration Date: October 06, 2015
Approval Date: October 06, 2010

R:\A - Projects\Project End\proj_1401_1500\BE_1478\RD_RMWC Drawings\WTG-700\S-4089.dwg, S-4089

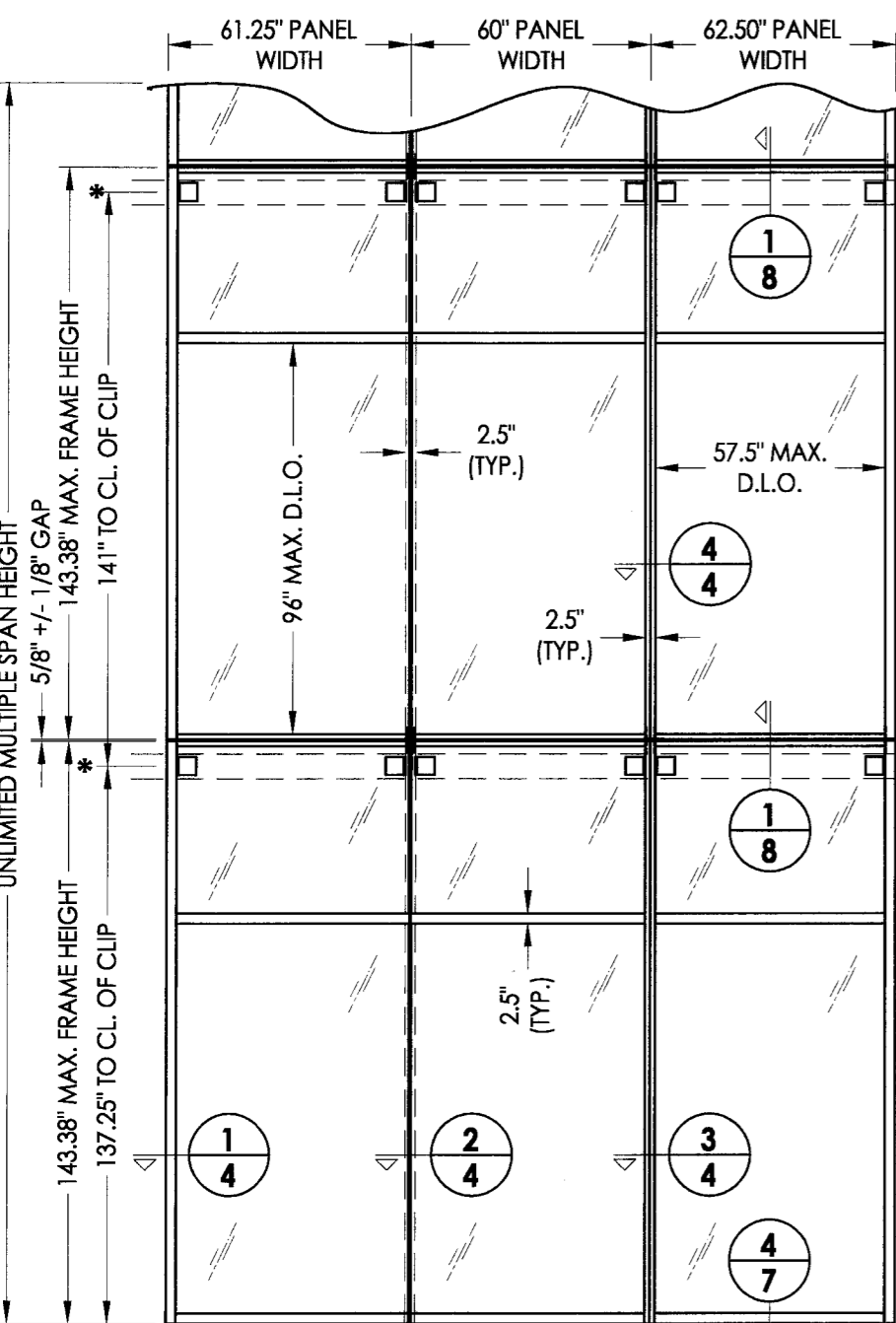

*Intermediate support location

MULTIPLE SPAN

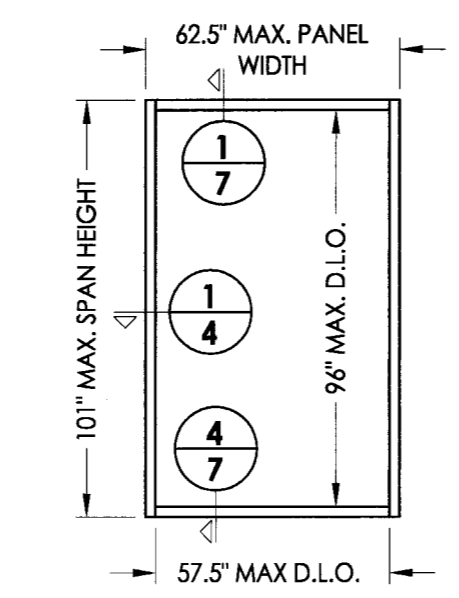

SINGLE PUNCHED OPENING

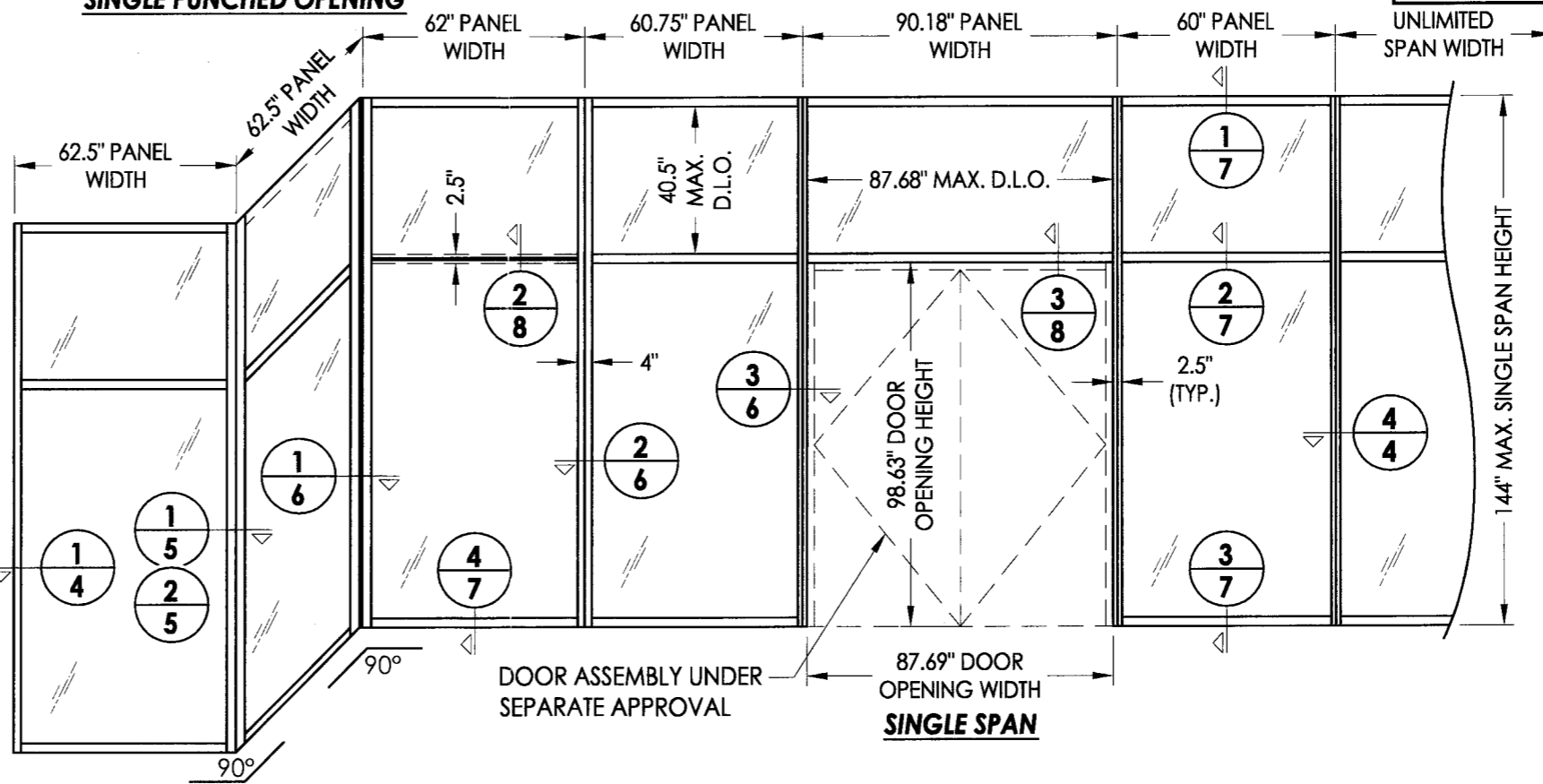

DOOR ASSEMBLY UNDER SEPARATE APPROVAL

SINGLE SPAN

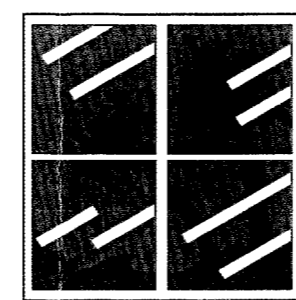

WEST TAMPA GLASS COMPANY

SINCE 1934

2705 N. 35th STREET
TAMPA, FLORIDA 33605

**SERIES WTG - 700
ALUMINUM CURTAIN WALL SYSTEM**

"SMALL MISSILE IMPACT"
(For use at 30 ft. or higher above grade only)

Approved as complying with the Florida Building Code
Date: OCT. 6, 2010
NO. 09-1202.03
Miami Trade Product Control
By: *Manuel Perez*

Documents Prepared By:
R.W. BUILDING CONSULTANTS, INC.
P.O. Box 230 Vairico FL 33595
Phone No.: 813.659.9197
Florida Board of Professional Engineers
Certificate of Authorization No. 9813
Ryan J. King 9-8-10
Ryan J. King, P.E. No. 64619

PRODUCT:
WEST TAMPA GLASS
SERIES WTG-700

PART OR ASSEMBLY:
TYPICAL ELEVATION
& DESIGN PRESSURES

SPAN TYPE	MAX. D.L.O. DIMENSION	MAX. TRANSOM D.L.O. DIMENSION	GLASS TYPE	DESIGN PRESSURE (PSF)**	
				POSITIVE	NEGATIVE
MULTIPLE SPAN	57.50" x 96.00"	N/A	G20, G21	+75.0	-75.0
			G3, G4	+90.0	-90.0
SINGLE SPAN	57.50" x 96.00"	87.68" x 40.87"	G20, G21	+75.0	-75.0
			G3, G4	+90.0	-90.0
SINGLE PUNCHED OPENING	57.50" x 96.00"	N/A	G20, G21	+75.0	-75.0
			G3, G4	+110.0	-110.0

**See sheet 4 for jamb/mullion reinforcement options and design pressure/span height limitations

TABLE OF CONTENTS			
SHEET #	DESCRIPTION	SHEET #	DESCRIPTION
1	Typical elevation & design pressures	10	Twin span details
2	General notes & glazing details	11	Anchoring
3	Glazing details	12	Anchoring
4	Horizontal cross sections	13	Face cover option details
5	Horizontal cross sections	14	Face cover option details
6	Horizontal cross sections	15	Components
7	Vertical cross sections	16	Components
8	Vertical cross sections	17	Components
9	Twin span details	18	Bill of materials

NO.	DATE	BY	REVISIONS
2	07/20/10	LFS	REVISED PER DADE COMMENTS
1	05/03/10	JK	REVISED PER DADE COMMENTS

DATE: 7/1/09
SCALE: N.T.S.
DWG. BY: AL
CHK. BY: LFS
DRAWING NO.: S-4089
SHEET 1 OF 18

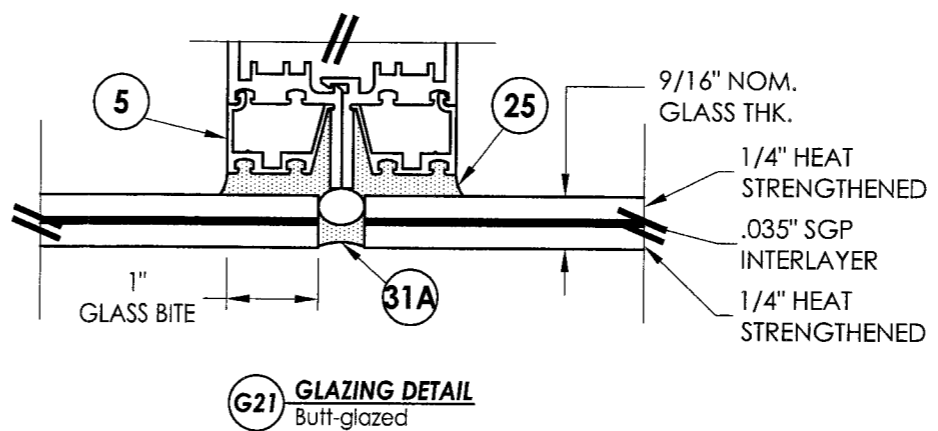
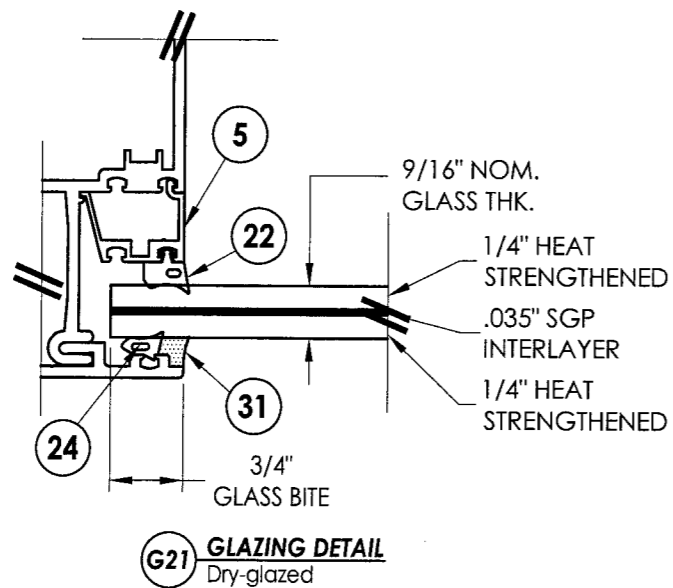
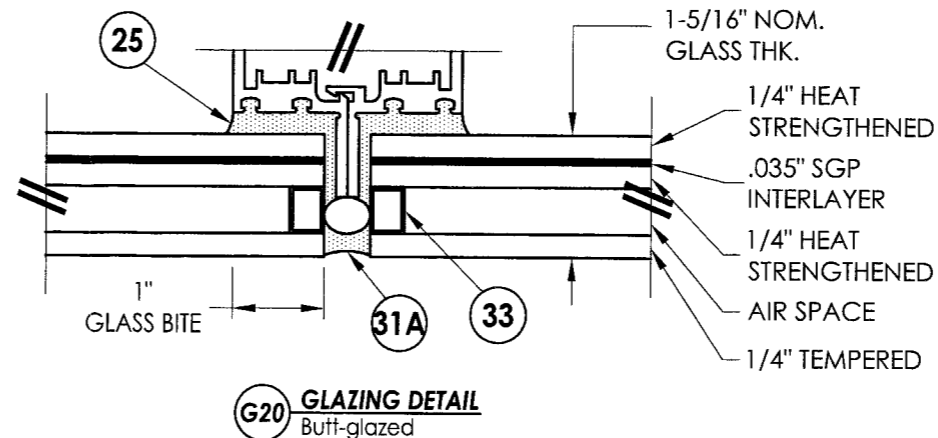
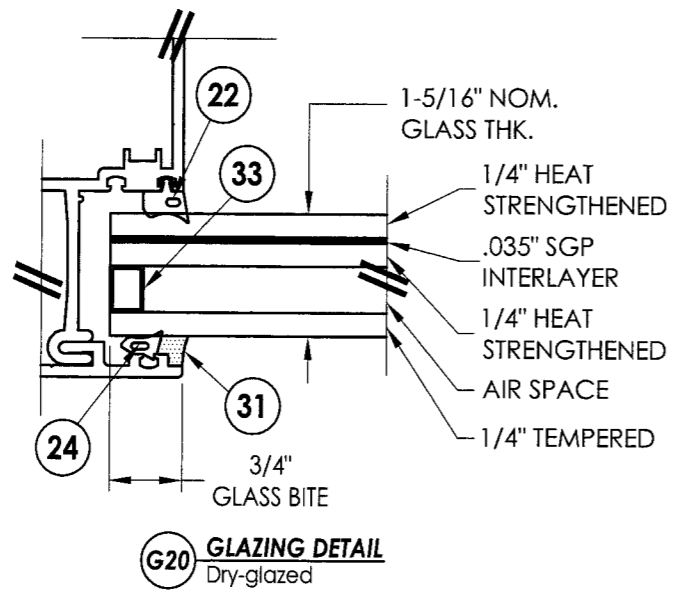

NOTES:

1. Head, sill & horizontal glazing details are similar to jamb details shown.
2. See sheets 13 & 14 for face cover option details.

Approved as complying with the Florida Building Code
Date: 08/09/2010
NO. 05-1202-03
Miami Dade Product Control
By: *[Signature]*

Documents Prepared By:		BUILDING CONSULTANTS, INC. P.O. Box 230 Vairico FL. 33595 Phone No.: 813.659.9197													
PRODUCT:		WEST TAMPA GLASS SERIES WTG-700													
PART OR ASSEMBLY:		GLAZING DETAILS													
REVISIONS		<table border="1"> <thead> <tr> <th>NO.</th> <th>DATE</th> <th>REVISED PER</th> <th>DADE COMMENTS</th> </tr> </thead> <tbody> <tr> <td>2</td> <td>7/20/10</td> <td>REVISOR</td> <td>PER DADE COMMENTS</td> </tr> <tr> <td>1</td> <td>05/03/10</td> <td>REVISOR</td> <td>PER DADE COMMENTS</td> </tr> </tbody> </table>		NO.	DATE	REVISED PER	DADE COMMENTS	2	7/20/10	REVISOR	PER DADE COMMENTS	1	05/03/10	REVISOR	PER DADE COMMENTS
NO.	DATE	REVISED PER	DADE COMMENTS												
2	7/20/10	REVISOR	PER DADE COMMENTS												
1	05/03/10	REVISOR	PER DADE COMMENTS												
DATE:		7/1/09													
SCALE:		N.T.S.													
DWG. BY:		AL													
CHK. BY:		LFS													
DRAWING NO.:		S-4089													
SHEET		3 of 18													

R:\A - Projects\Project Folders\proj 1401-1500\PF 1478\1478.D. RWBC Drawings\WTG-700\14089\14089.dwg, 4

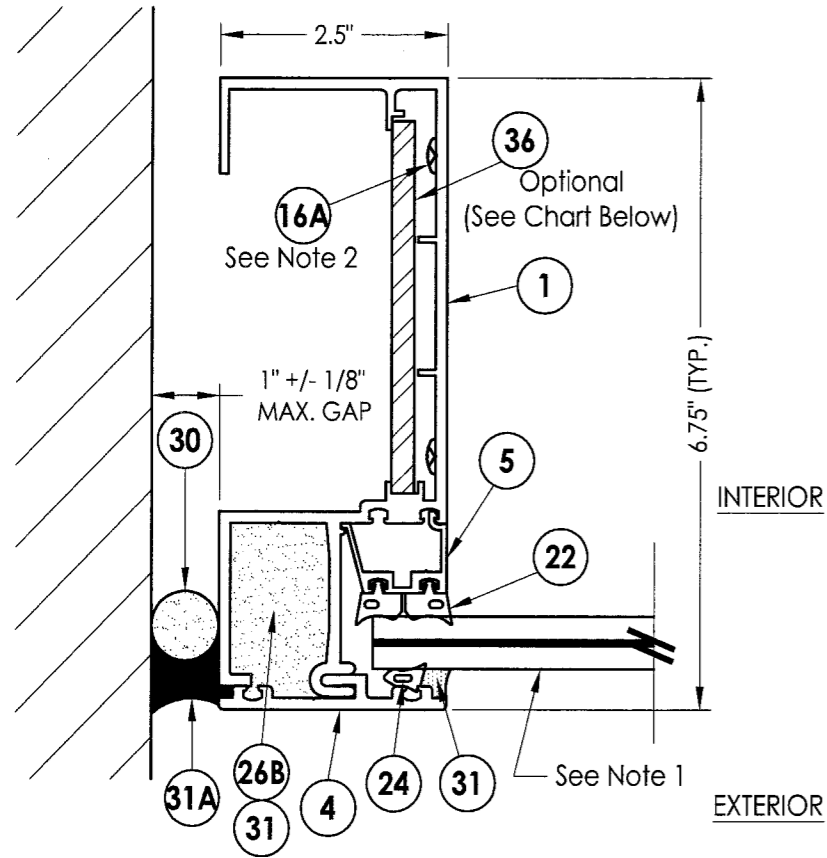

1 **HORIZONTAL CROSS SECTION**
4 Jamb Detail
 Dry Glazed Option
 Total Ix (Aluminum) = 15.189 in.⁴

Material Properties Chart			
MATERIAL	ITEM	Sx (in ³)	Ix (in ⁴)
Aluminum	1	3.108	10.362
	12	1.642	5.745
	12A	1.561	4.646
	13	1.560	5.413
	13A	1.464	4.329
Steel	36	0.667	1.333
	36A	0.333	0.667
	36B	1.021	1.786

- NOTES:
- See sheets 2 & 3 for glazing option details and sheets 13 & 14 for face cover option details.
 - Attach the head and sill to the jambs/mullions w/ (3) item 16A at each end. Attach the intermediate/twin span rails to the jambs/mullions w/ (4) item 16A at each end. See the corner connection detail on this sheet.

Design Pressure Ratings / Maximum Frame Heights					
SPAN TYPE	REINFORCEMENT REQUIRED		MAX. FRAME HEIGHT	DESIGN PRESSURE (PSF)	
	JAMBS	MULLIONS		POSITIVE	NEGATIVE
Single Punched Opening	NONE	N/A	101"	+ 110	- 110
Single Span	NONE	LIGHT	132"	+ 90	- 90
	LIGHT	HEAVY	144"	+ 90	- 90
Multiple Span	NONE	LIGHT	132"	+ 90	- 90
	LIGHT	HEAVY	143.38"	+ 74	- 74
			143.38"	+ 90	- 90

NOTE: Maximum frame heights in the table correspond to the max. frame widths shown on the elevation, sheet 1.

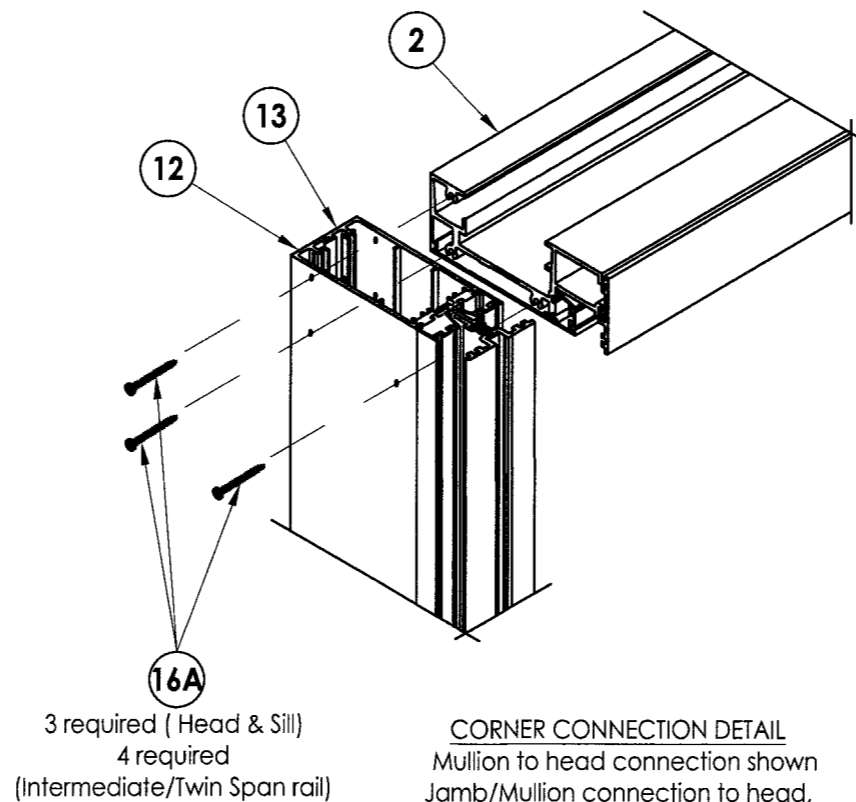

16A
 3 required (Head & Sill)
 4 required
 (Intermediate/Twin Span rail)

CORNER CONNECTION DETAIL
 Mullion to head connection shown
 Jamb/Mullion connection to head,
 sill and intermediate/Twin Span rail is similar.

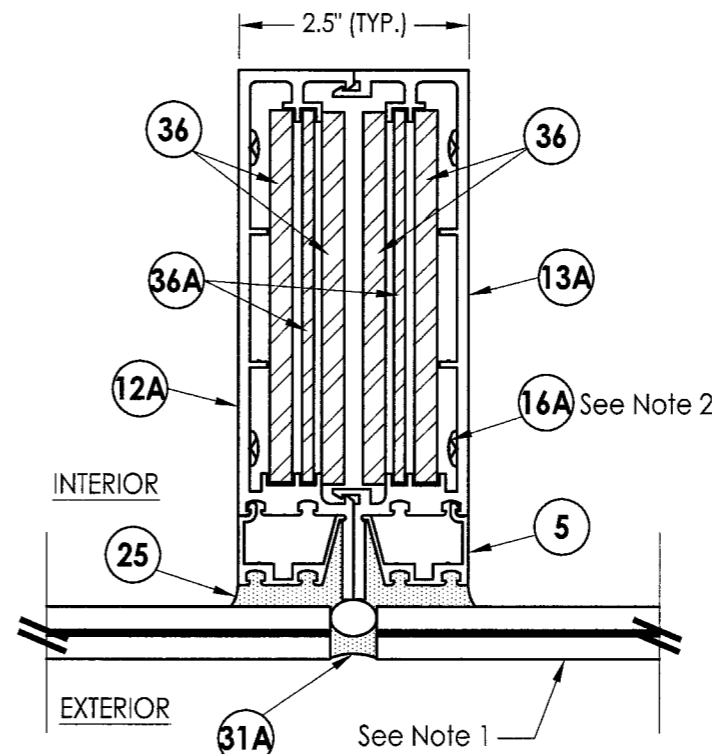

2 **HORIZONTAL CROSS SECTION**
4 Intermediate Vertical Mullion Detail
 w/ Heavy Reinforcement - Structural Glazed Option
 Total Ix (Aluminum) = 31.183 in.⁴ (Dry Glazed)
 Total Ix (Aluminum) = 28.482 in.⁴ (Str. Glazed)

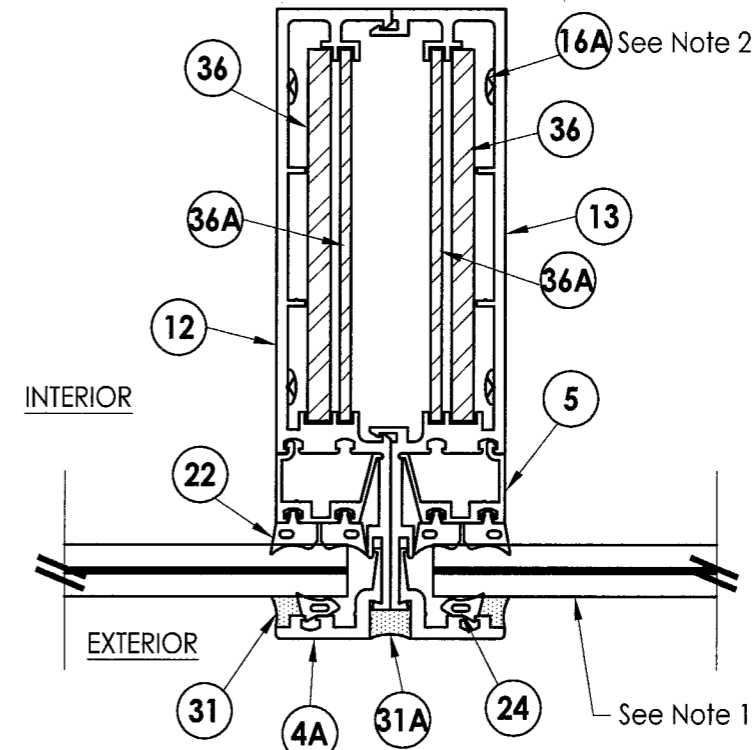

3 **HORIZONTAL CROSS SECTION**
4 Intermediate Vertical Mullion Detail
 w/ Light Reinforcement - Dry Glazed Option
 Total Ix (Aluminum) = 23.384 in.⁴ (Dry Glazed)
 Total Ix (Aluminum) = 20.733 in.⁴ (Str. Glazed)

Approved as engineering with the Florida Building Code
 Date 09-16-2010
 No. 09-1202-03
 Miami Dade Product Control Division
 By: *Manuel Lopez*

Documents Prepared By: **R.W. BUILDING CONSULTANTS, INC.**
 P.O. Box 230 Vairico FL 33595
 Phone No.: 813.659.9197
 Florida Board of Professional Engineers
 Certificate Of Authorization No. 9813
 Ryan J. King, P.E. No. 64619

PRODUCT: WEST TAMPA GLASS SERIES WTG-700
 PART OR ASSEMBLY: HORIZONTAL CROSS SECTIONS

NO.	DATE	REVISIONS
2	7/20/10	REVISED PER DADE COMMENTS
1	05/03/10	REVISED PER DADE COMMENTS

DATE: 7/1/09
 SCALE: N.T.S.
 DWG. BY: AL
 CHK. BY: LFS
 DRAWING NO.: S-4089
 SHEET 4 of 18

© 2009 R.W. BUILDING CONSULTANTS INC.

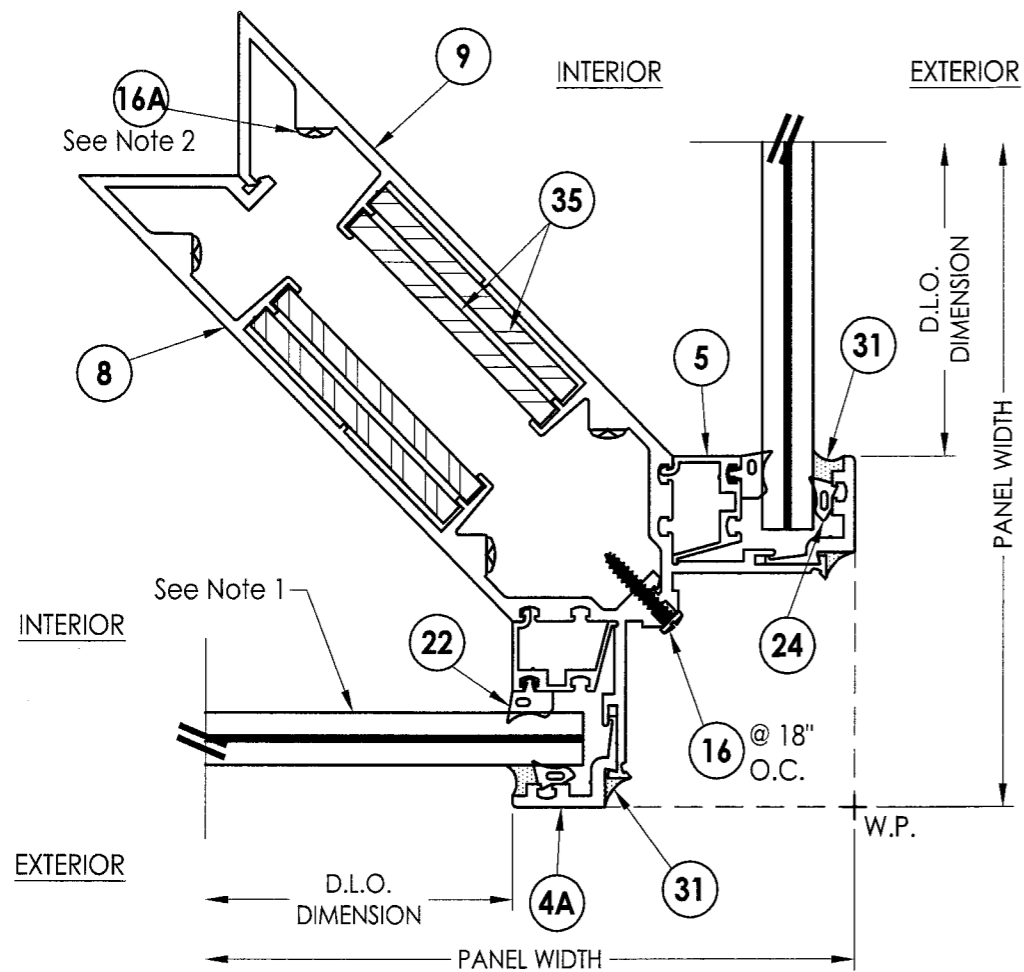

1 **HORIZONTAL CROSS SECTION**
5 Exterior 90 deg. Corner Mullion Detail w/ Trim Dry Glazed Option

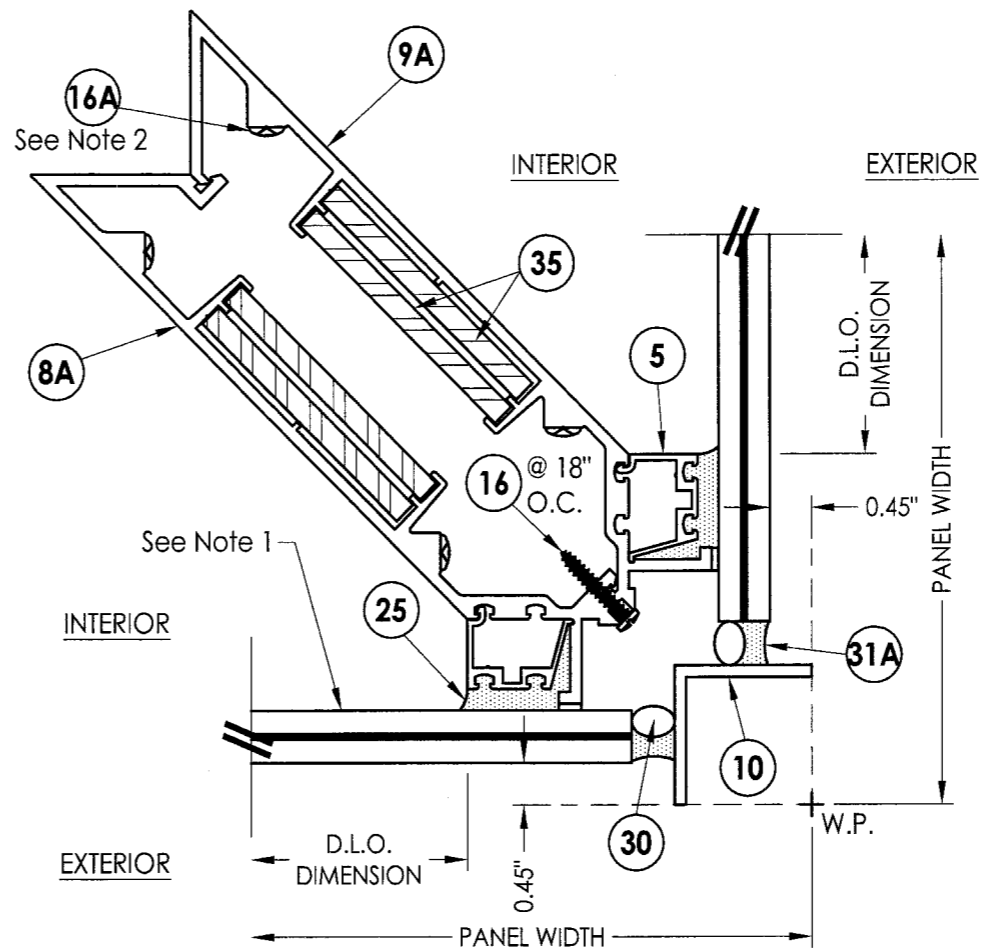

2 **HORIZONTAL CROSS SECTION**
5 Exterior 90 deg. Corner Mullion Detail w/o Trim Structural Glazed Option

NOTES:

- See sheets 2 & 3 for glazing option details and sheets 13 & 14 for face cover option details.
- Attach the head and sill to the corner mullion w/ (3) item 16A at each end. Attach the intermediate rails to the corner mullion w/ (4) item 16A at each end. See the corner connection detail on sheet 4.

Approved as complying with the Florida Building Code
 Date: 08/19/2010
 NCAP 08-1202-03
 Miami Dade Product Control
 By: *Manuel Flores*

Documents Prepared By:

RW
 BUILDING CONSULTANTS, INC.
 P.O. Box 230 Valrico FL 33595
 Phone No.: 813.659.9197
 Florida Board of Professional Engineers
 Certificate Of Authorization No. 9813
Ryan J. King 9-8-10
 Ryan J. King, P.E. No. 64619

PRODUCT:
 WEST TAMPA GLASS
 SERIES WTG-700

PART OR ASSEMBLY:
 HORIZONTAL CROSS SECTIONS

NO.	DATE	REVISIONS
2	7/20/10	REVISED PER DADE COMMENTS LFS
1	05/03/10	REVISED PER DADE COMMENTS JK
		BY

DATE: 7/1/09

SCALE: N.T.S.

DWG. BY: AL

CHK. BY: LFS

DRAWING NO.:
 S-4089

SHEET 5 OF 18

R:\A - Projects\Project Folders\proj_1401-1500\PF 1478\ID. RWBC Drawings\WTG-700\S-4089\S-4089.dwg, 7

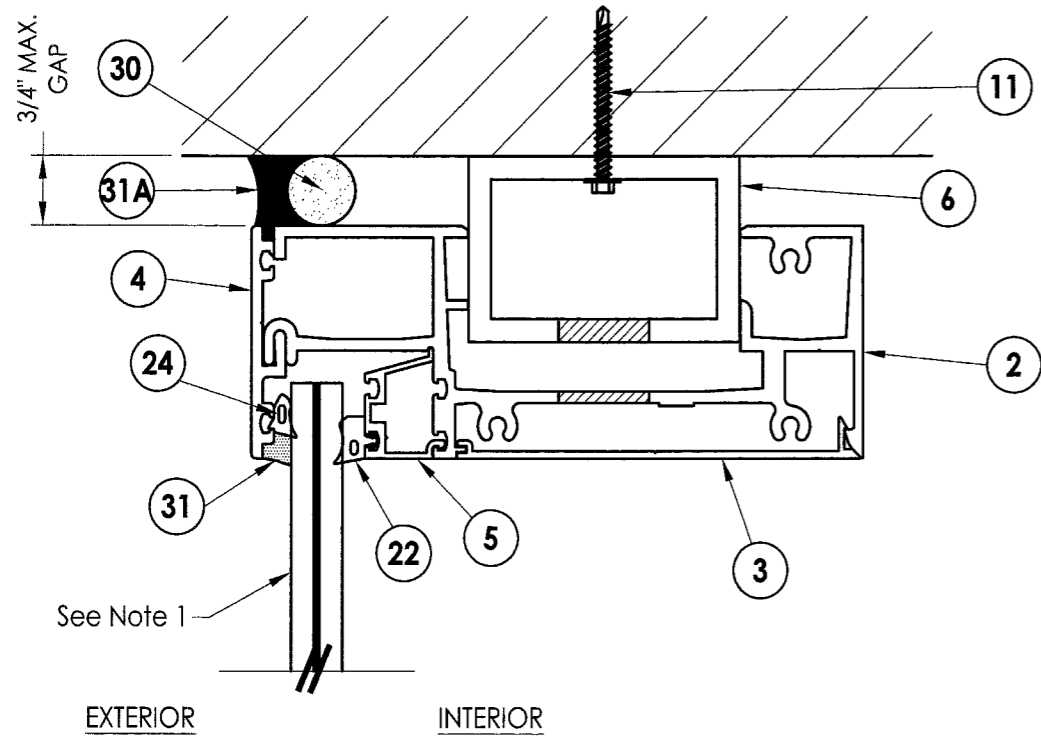

1 VERTICAL CROSS SECTION
7 Head Detail
Dry Glazed Option

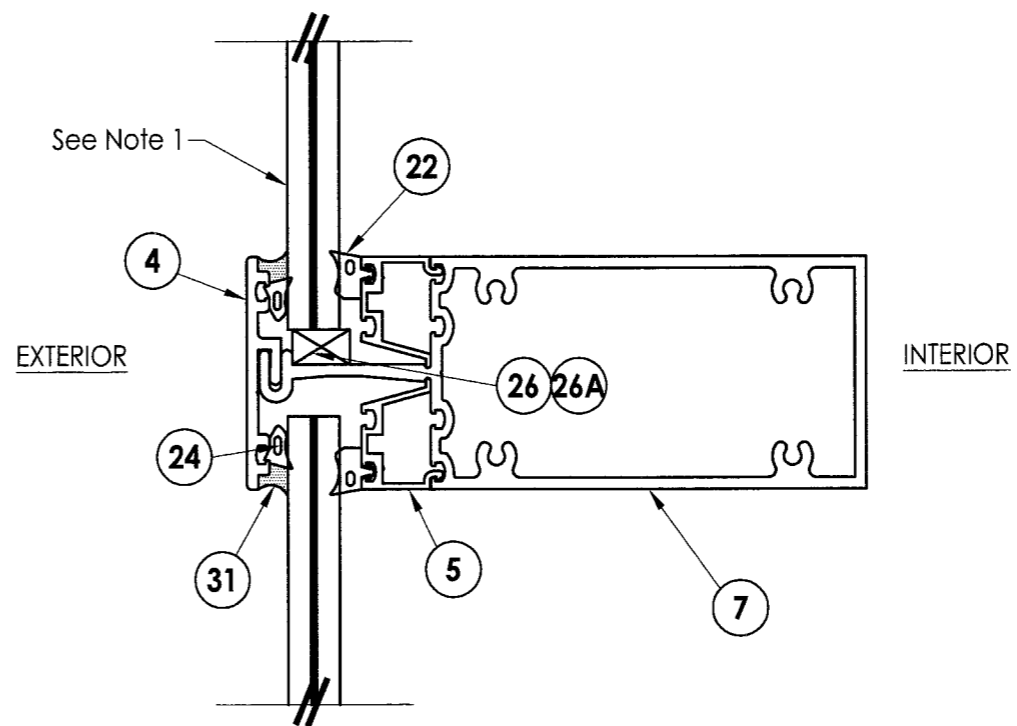

2 VERTICAL CROSS SECTION
7 Intermediate Horizontal Mullion Detail
Dry Glazed Option

NOTES:
1. See sheets 2 & 3 for glazing option details and sheets 13 & 14 for face cover option details.

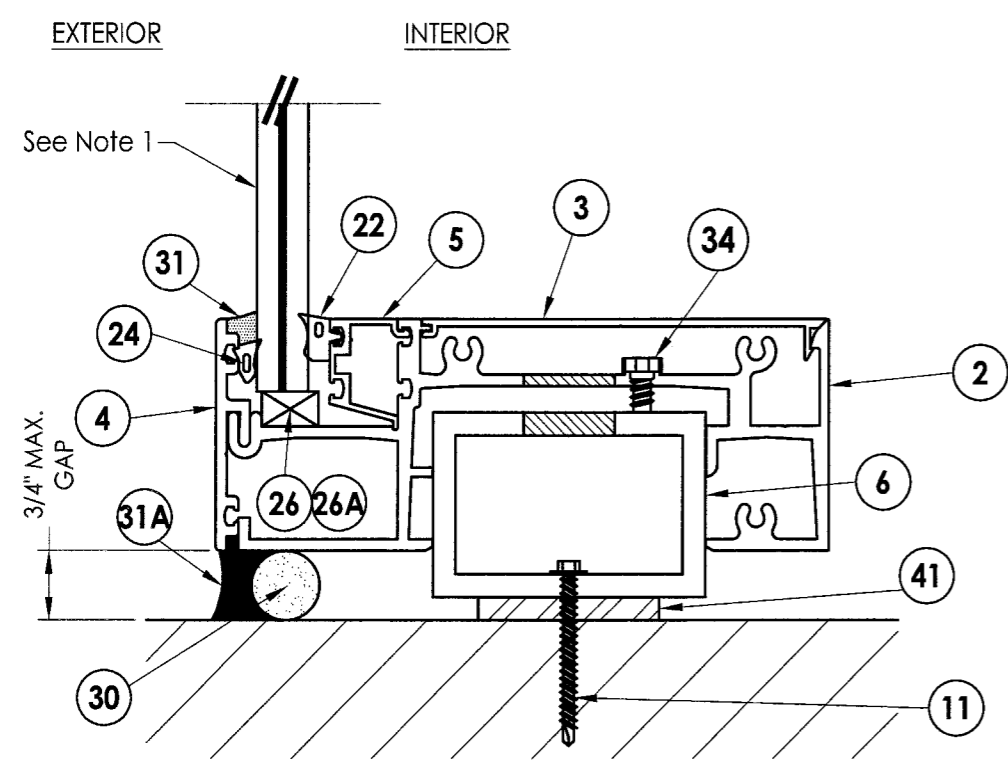

3 VERTICAL CROSS SECTION
7 Sill Detail w/ Steel Angle Clip
Dry Glazed Option

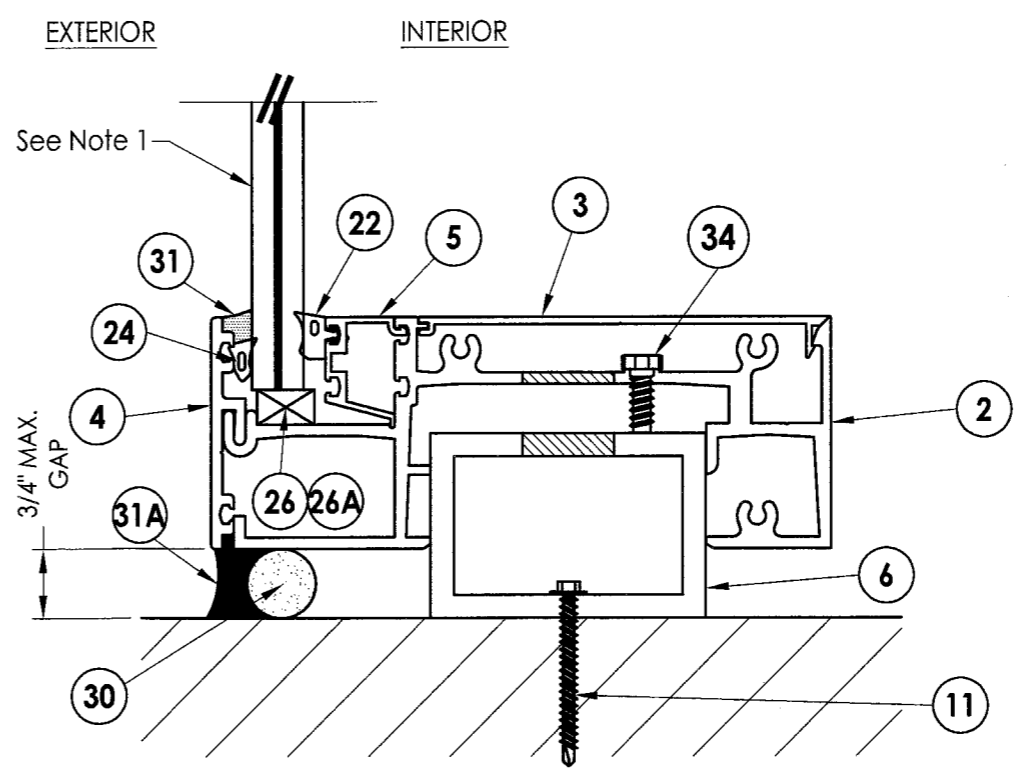

4 VERTICAL CROSS SECTION
7 Sill Detail
Dry Glazed Option

Approved as complying with the Florida Building Code
Date: 08/20/10
By: M. J. King
R. W. Building Consultants, Inc.
P.O. Box 230 Valrico FL 33595
Phone No.: 813.659.9197
Florida Board of Professional Engineers
Certificate of Authorization No. 9813
Ryan J. King, P.E. No. 64619

Documents Prepared By:		BUILDING CONSULTANTS, INC. P.O. Box 230 Valrico FL 33595 Phone No.: 813.659.9197	
PRODUCT:		WEST TAMPA GLASS SERIES WTG-700	
PART OR ASSEMBLY:		VERTICAL CROSS SECTIONS	
NO.	DATE	REVISIONS	BY
2	7/20/10	REVISED PER DADE COMMENTS	LFS
1	05/03/10	REVISED PER DADE COMMENTS	JK
DATE:		7/1/09	
SCALE:		N.T.S.	
DWG. BY:		AL	
CHK. BY:		LFS	
DRAWING NO.:		S-4089	
SHEET		7 OF 18	

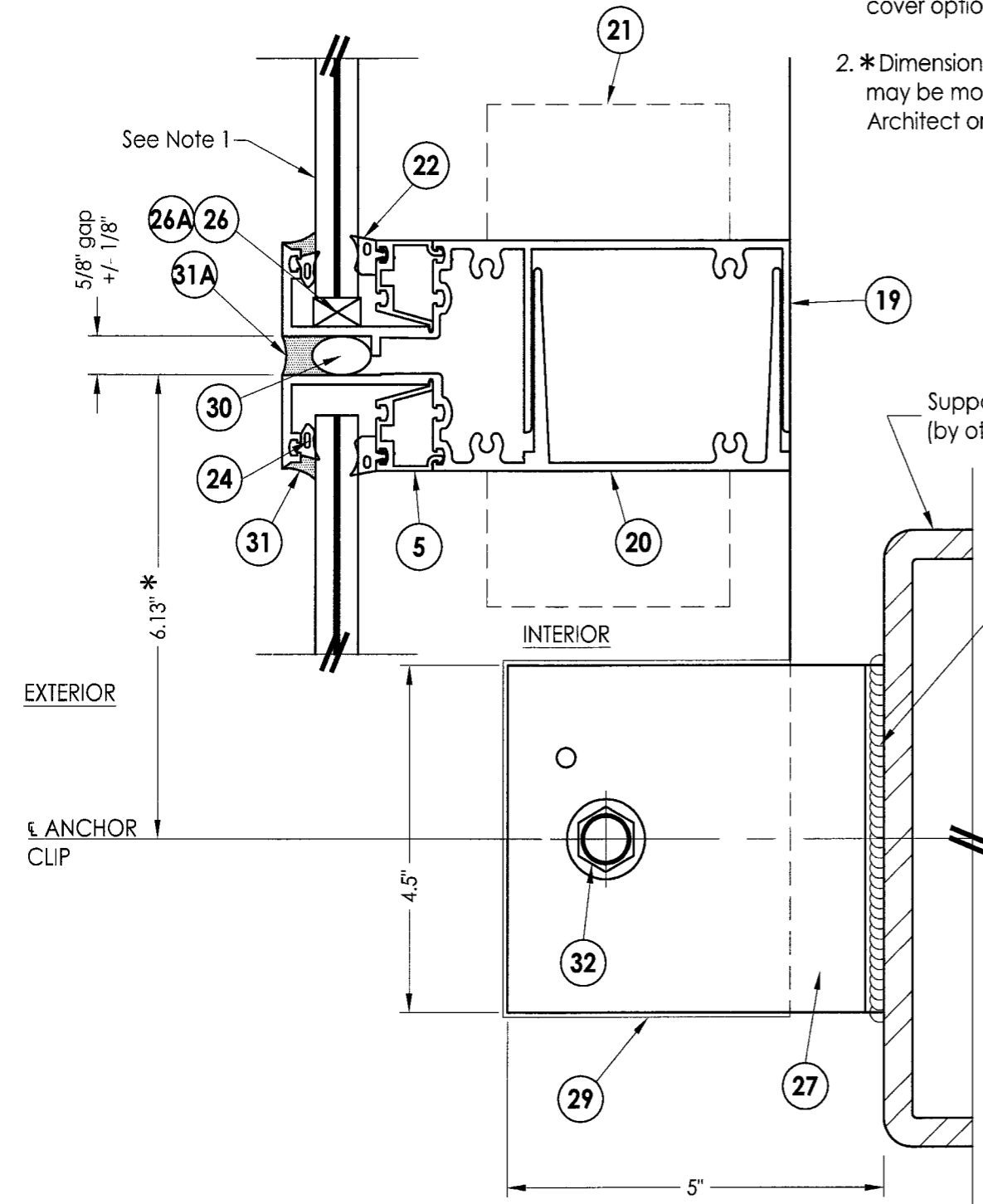

1 **VERTICAL CROSS SECTION**
8 Intermediate Anchor & Splice Detail

- NOTES:
1. See sheets 2 & 3 for glazing option details and sheets 13 & 14 for face cover option details.
 2. *Dimension shown as tested and may be modified as specified by the Architect or Engineer of Record.

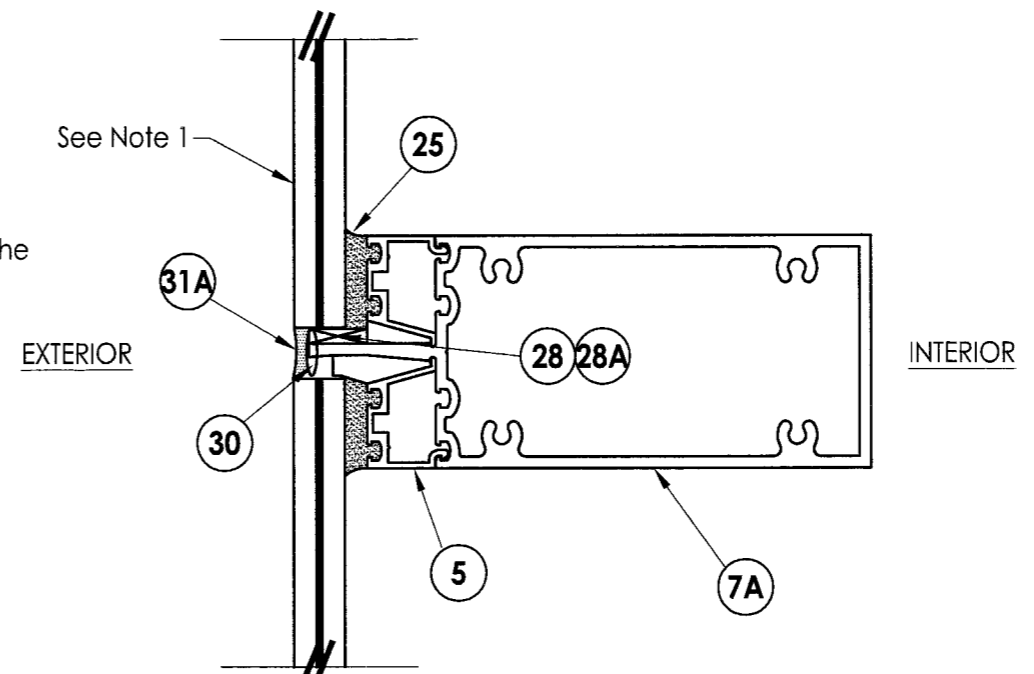

2 **VERTICAL CROSS SECTION**
8 Intermediate Horizontal Mullion Detail Structural Glazed Option

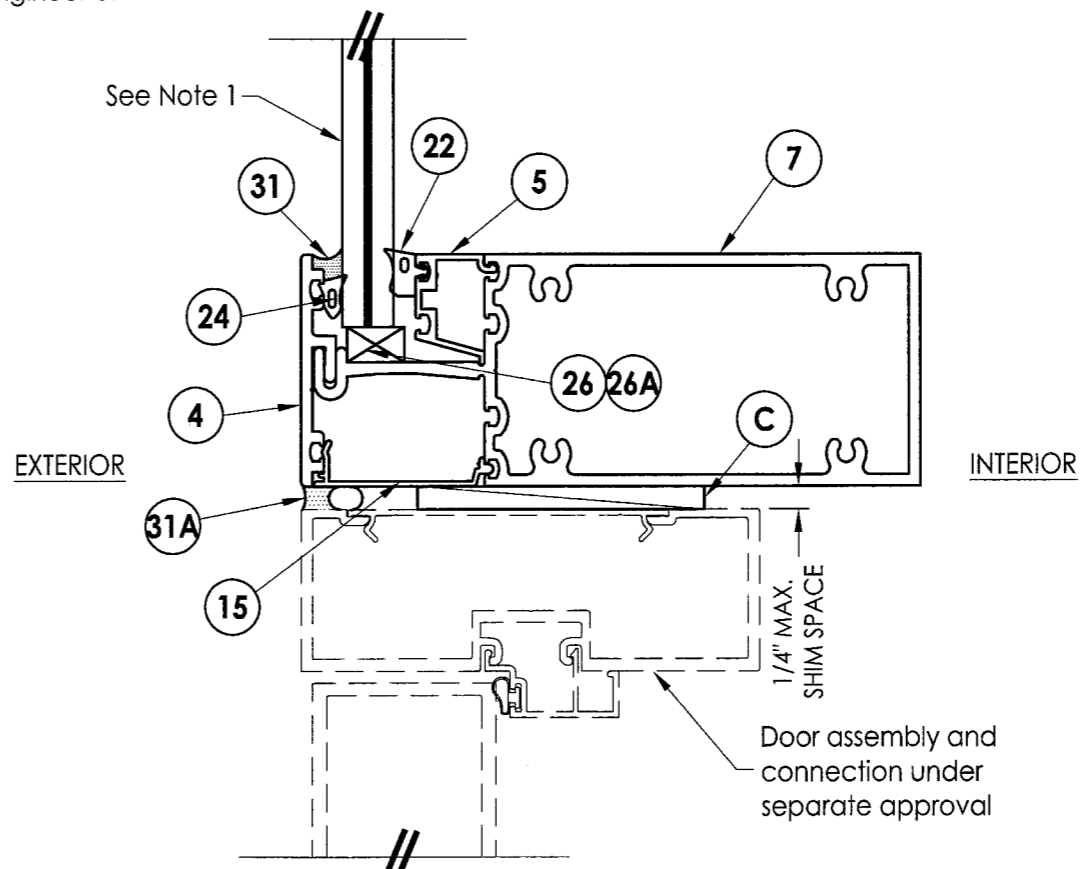

3 **VERTICAL CROSS SECTION**
8 Intermediate Horizontal Mullion/Door Header Detail

Approved as complying with the Florida Building Code
Date: 08/06/2010
NOAF: 05-1202.03
Miami Code Product Control
By: *James J. King*

Documents Prepared By:

RW BUILDING CONSULTANTS, INC.
P.O. Box 230 Valrico FL 33595
Phone No.: 813.659.9197
Florida Board of Professional Engineers
Certificate of Authorization No. 9813
James J. King 1-8-10
Ryan J. King, P.E. No. 64619

PRODUCT:
WEST TAMPA GLASS
SERIES WTG-700

PART OR ASSEMBLY:
VERTICAL CROSS SECTIONS

NO	DATE	REVISIONS
2	7/20/10	REVISED PER DADE COMMENTS LFS
1	05/03/10	REVISED PER DADE COMMENTS JK
		BY

DATE: 7/1/09
SCALE: N.T.S.
DWG. BY: AL
CHK. BY: LFS
DRAWING NO.: S-4089
SHEET 8 OF 18

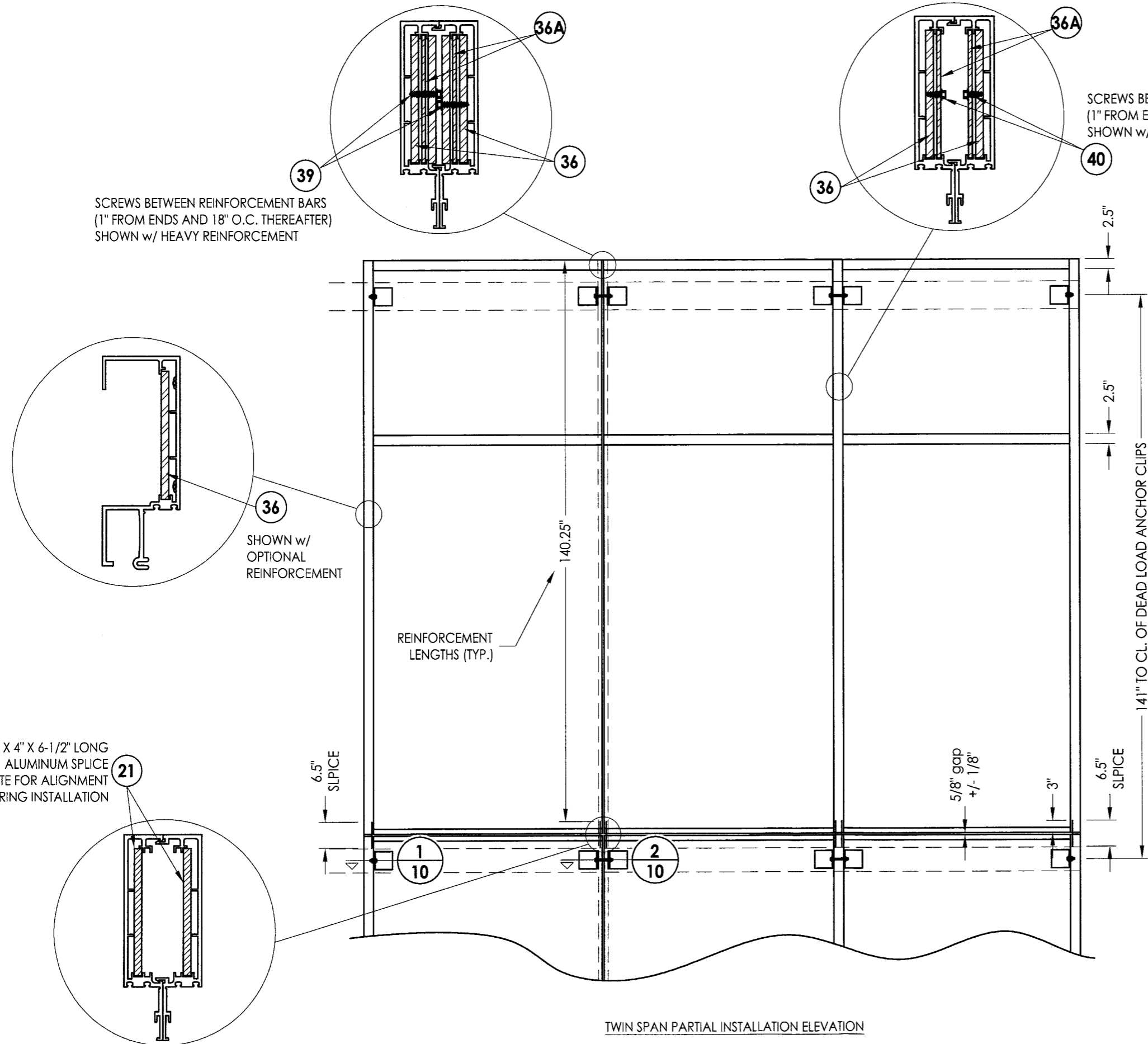

TWIN SPAN PARTIAL INSTALLATION ELEVATION

Approved as complying with the Florida Building Code
 Date: 08/09/2010
 NO. 07-1202.03
 Miami Dade Product Control
 By: *Manual Day*

Documents Prepared By: R.W. BUILDING CONSULTANTS, INC. P.O. Box 230 Valrico FL 33595 Phone No.: 813.659.9197 Florida Board of Professional Engineers Certificate Of Authorization No. 9813 <i>Ryan J. King</i> 9-8-10 Ryan J. King, P.E. No. 64619	
PRODUCT: WEST TAMPA GLASS SERIES WTG-700	PART OR ASSEMBLY: TWIN SPAN DETAILS
REVISIONS	NO. DATE 2 7/20/10 REVISED PER DADE COMMENTS 1 105/03/10 REVISED PER DADE COMMENTS
DATE: 7/1/09	SCALE: N.T.S.
DWG. BY: AL	CHK. BY: LFS
DRAWING NO.: S-4089	SHEET 9 OF 18

R:\A - Projects\Project Folders\proj 1401-1500\PF 1478\D. RWBC Drawings\WTG-700\S-4089.dwg, 10

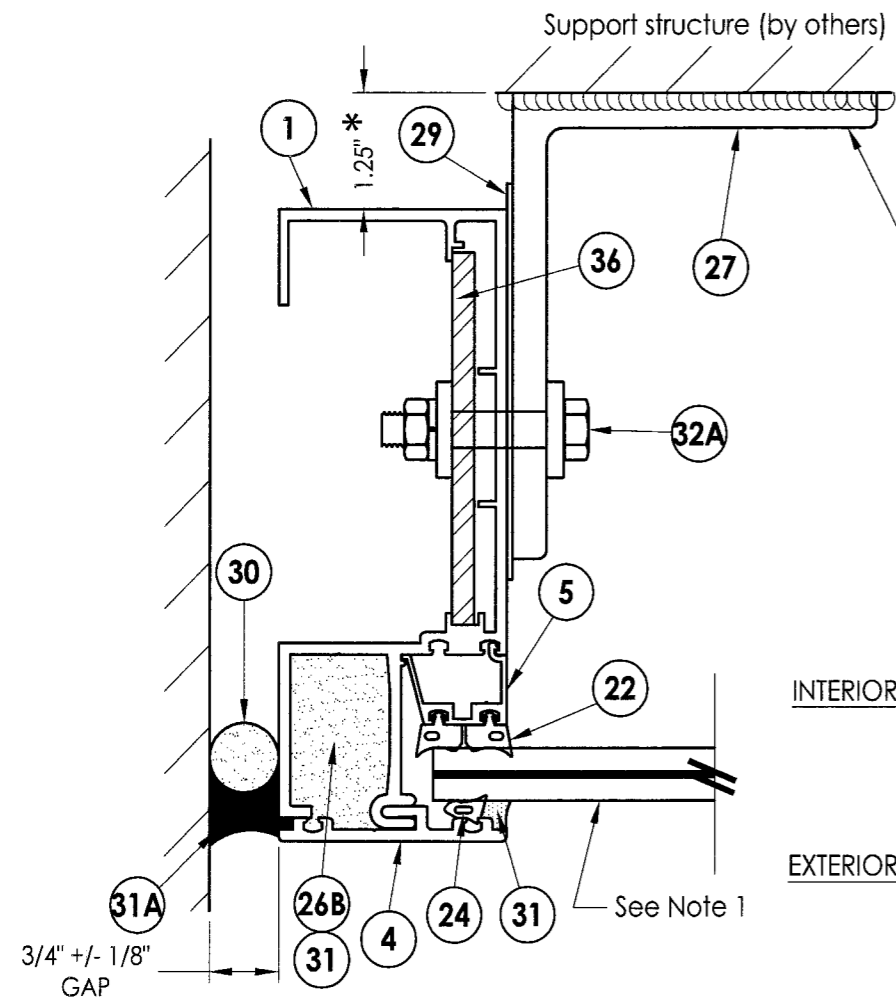

1 **HORIZONTAL CROSS SECTION**
10 Intermediate Jamb Deadload Anchor Detail
 Dry Glazed Option

Anchoring of curtain wall system to supporting structure is the responsibility of the Architect or Engineer of Record.

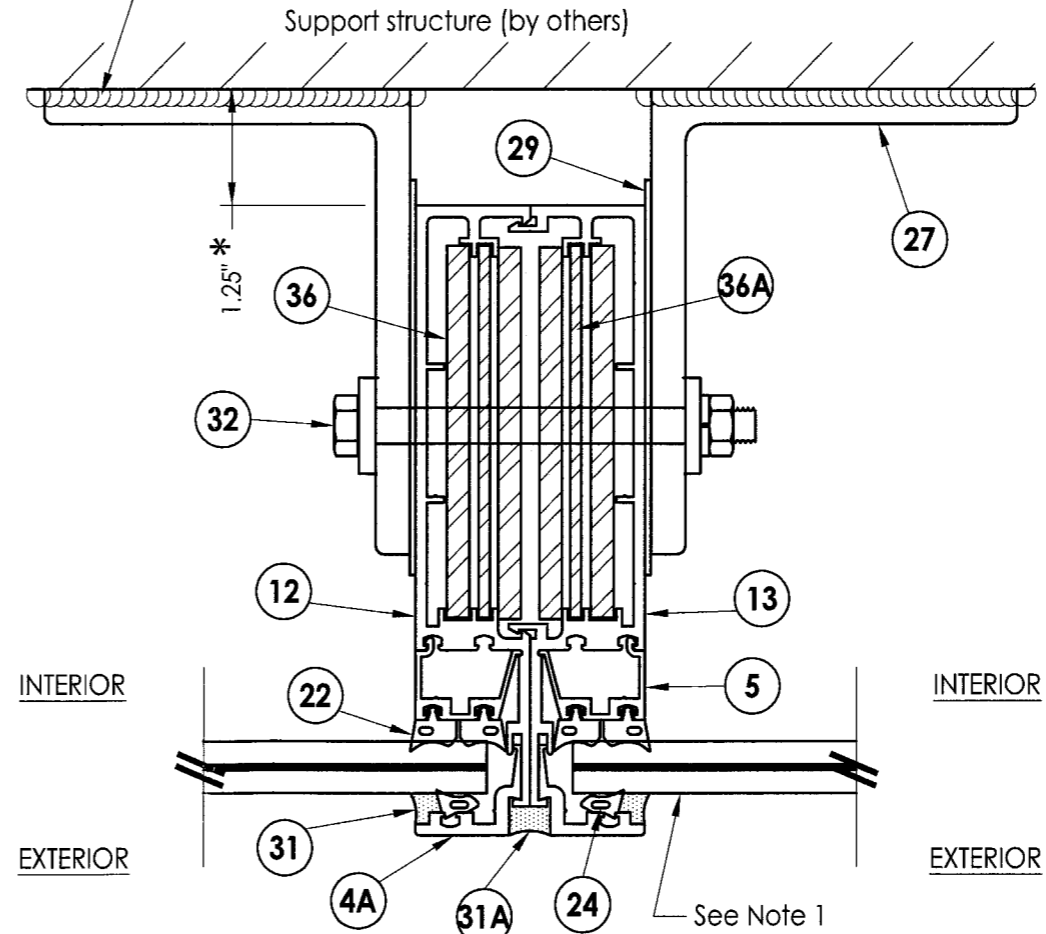

2 **HORIZONTAL CROSS SECTION**
10 Intermediate Mullion Deadload Anchor Detail
 Dry Glazed Option

- NOTES:
- See sheets 2 & 3 for glazing option details and sheets 13 & 14 for face cover option details.
 - *Dimension shown as tested and may be modified as specified by the Architect or Engineer of Record.

Approved as complying with the Florida Building Code
 Date **05-19-2010**
 NCAS **09-1202-03**
 Miami Dade Product Control Division
 By *Maureen Ruiz*

Documents Prepared By:
RW BUILDING CONSULTANTS, INC.
 P.O. Box 230 Valrico FL 33595
 Phone No.: 813.659.9197
 Florida Board of Professional Engineers
 Certificate Of Authorization No. 9813
Ryan J. King 9-8-10
 Ryan J. King, P.E. No. 64619

PRODUCT: WEST TAMPA GLASS SERIES WTG-700

PART OR ASSEMBLY: TWIN SPAN DETAILS

NO.	DATE	REVISIONS
2	7/20/10	REVISED PER DADE COMMENTS LFS
1	05/03/10	REVISED PER DADE COMMENTS JK
		BY

DATE: 7/1/09
 SCALE: N.T.S.
 DWG. BY: AL
 CHK. BY: LFS
 DRAWING NO.: S-4089
 SHEET 10 of 18

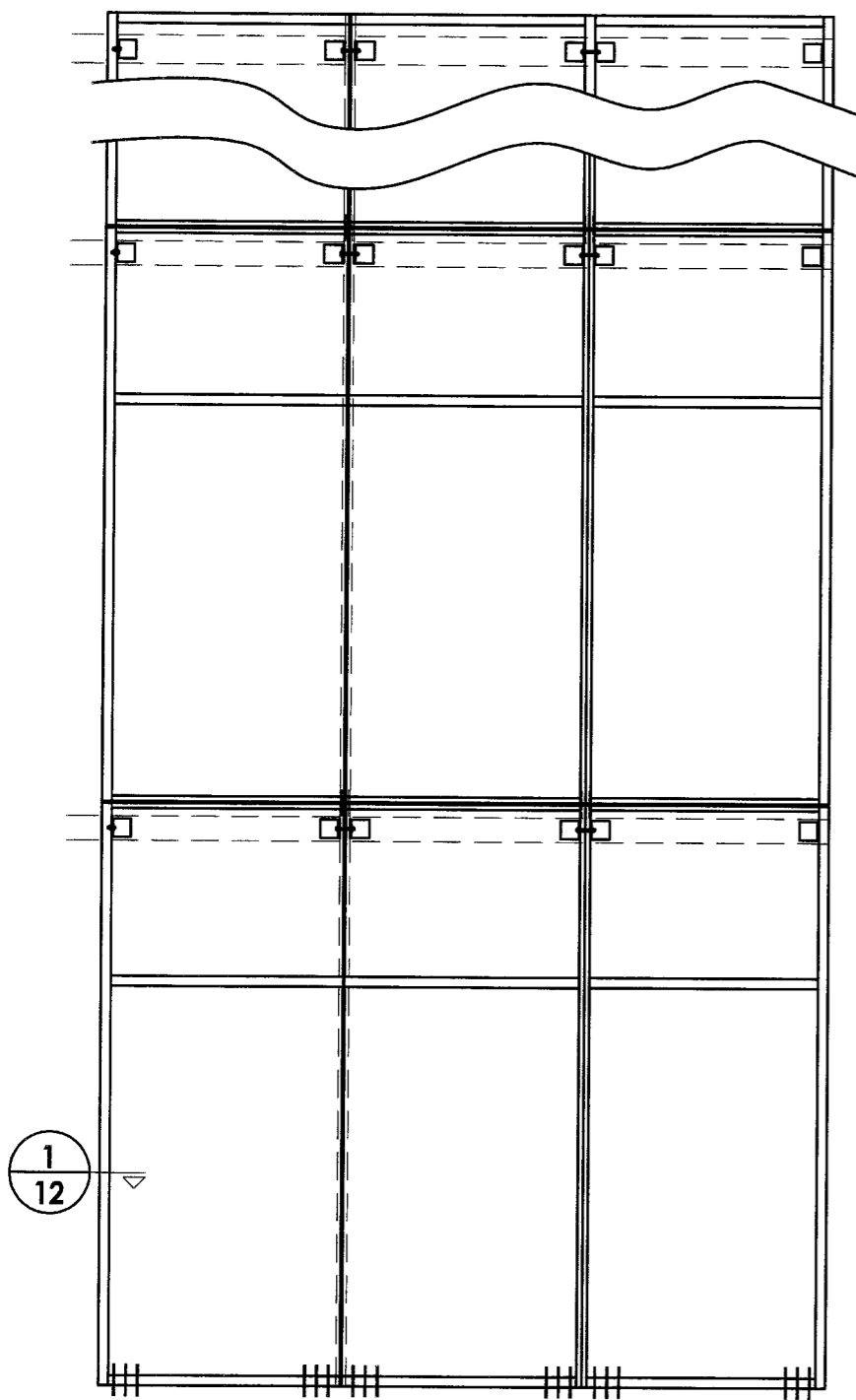

MULTIPLE SPAN FRAME ANCHORING
MAX. DP <= 90 PSF (MULTIPLE SPAN)

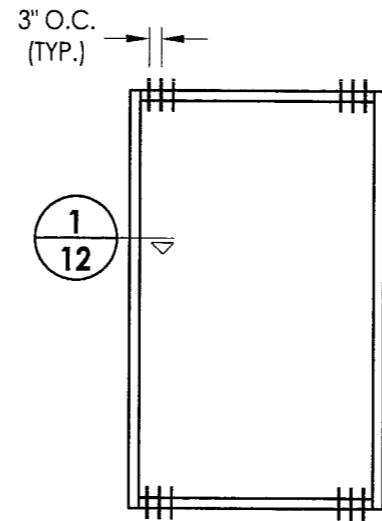

SINGLE PUNCHED OPENING FRAME ANCHORING
MAX. DP <= 110 PSF

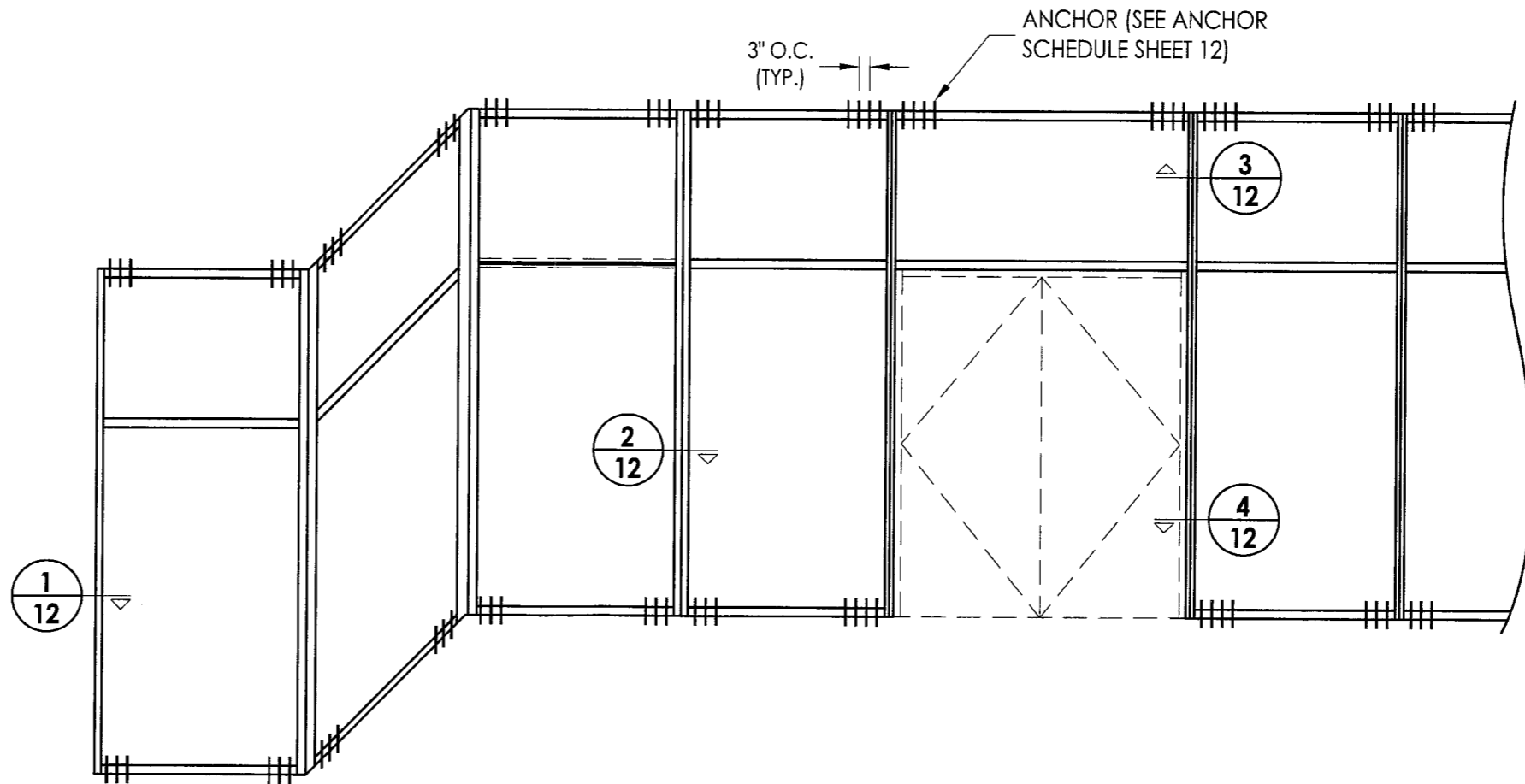

SINGLE SPAN FRAME ANCHORING
MAX. DP <= 90 PSF (SINGLE SPAN)

Approved as complying with the Florida Building Code
Date: **OCT. 6 2010**
NGA# **01-1702.03**
Miami Dade Product Control
By: *M. Manuel*

Documents Prepared By:
R.W. BUILDING CONSULTANTS, INC.
P.O. Box 230 Valrico FL 33595
Phone No.: 813.659.9197
Florida Board of Professional Engineers
Certificate of Authorization No. 9813
M. Manuel 7-8-10
Ryan J. King, P.E. No. 64619

PRODUCT: WEST TAMPA GLASS SERIES WTG-700
PART OR ASSEMBLY: ANCHORING

NO.	DATE	REVISIONS
2	7/20/10	REVISED PER DADE COMMENTS
1	05/03/10	REVISED PER DADE COMMENTS

DATE: 7/1/09
SCALE: N.T.S.
DWG. BY: AL
CHK. BY: LFS
DRAWING NO.: S-4089
SHEET 11 of 18

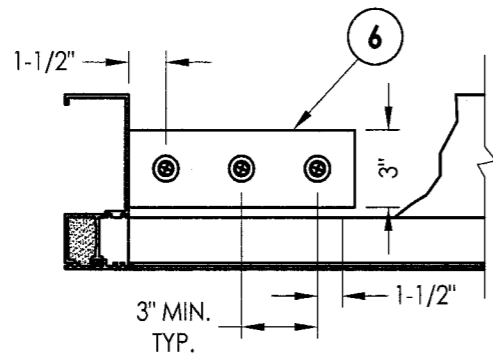

1
12 **HORIZONTAL CROSS SECTION @ JAMB**
Sill & sill cover partially removed for clarity
Anchor @ head similar

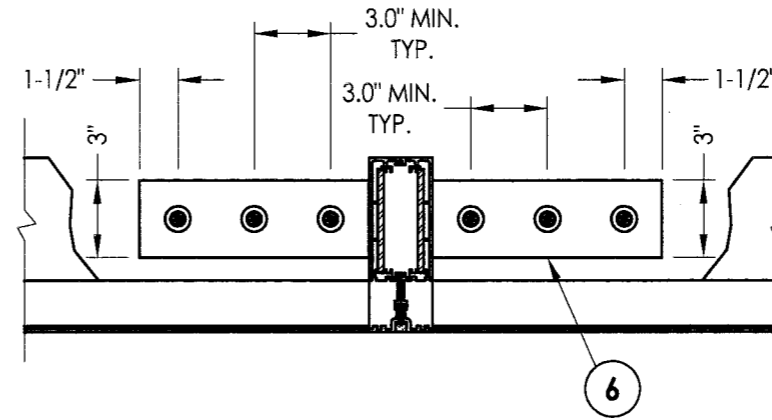

2
12 **HORIZONTAL CROSS SECTION @ VERTICAL**
Sill & sill cover partially removed for clarity
Anchor @ head similar

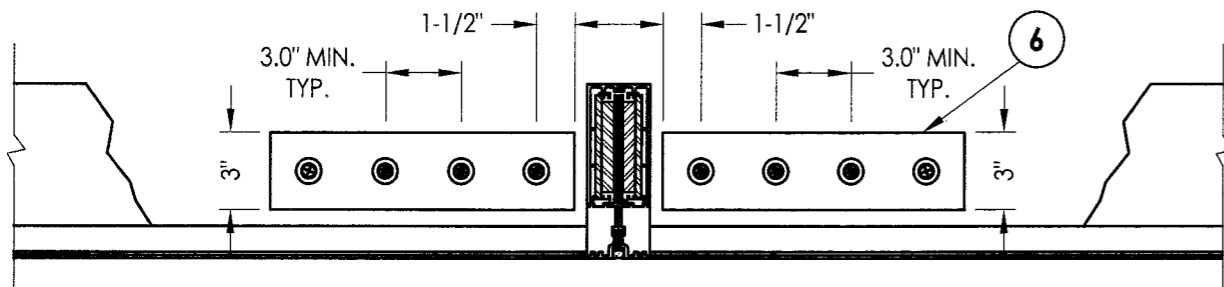

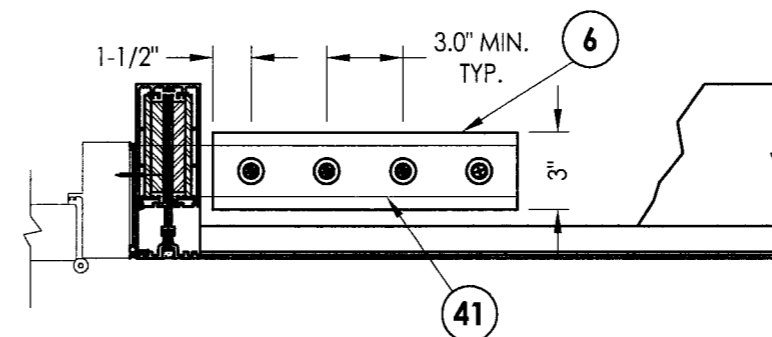

3
12 **HORIZONTAL CROSS SECTION @ DOOR JAMB**
Head & head cover partially removed for clarity

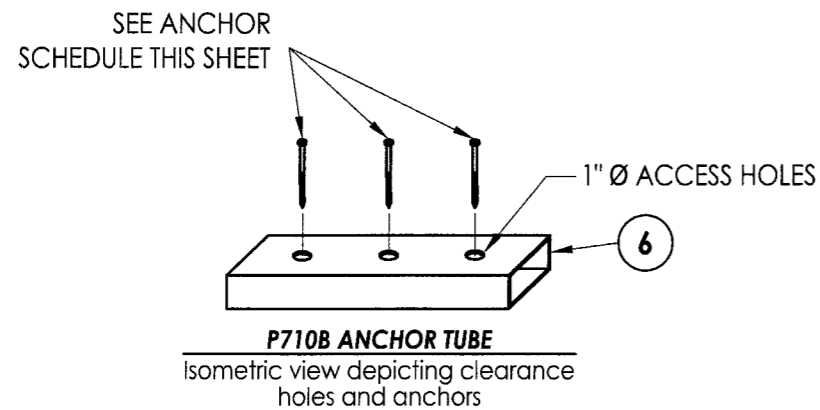

4
12 **HORIZONTAL CROSS SECTION @ DOOR JAMB**
Sill & sill cover partially removed for clarity



ANCHOR SCHEDULE	
SUBSTRATE	ANCHOR
CONCRETE: 	5/16" DIA. X 2-3/4" ITW HWH TAPCON ANCHOR WITH 2.25" MIN. EMBEDMENT, 2-3/16" MIN EDGE DISTANCE & 3.0" MIN. CENTERLINE DISTANCE. CONCRETE CONFORMING TO ACI 301 (3,192 PSI MIN.)
STEEL: 	1/4-20 X 1-1/2" HWH #4 KWIK-FLEX SELF DRILLING SCREW (A MINIMUM OF 3 THREADS SHALL PROTRUDE THROUGH THE STEEL SUBSTRATE) STEEL CONFORMING TO ASTM A653, .125" MIN. WALL THICKNESS Fy = 33,000 PSI, Fu = 45,000 PSI

Approved as complying with the Florida Building Code
 Date: 08-19-03
 NCAP: 08-19-03
 Miami Dade Product Control
 By: *Manuel Perez*

Documents Prepared By: **RW** BUILDING CONSULTANTS, INC.
 P.O. Box 230 Vairco FL 33595
 Phone No.: 813.659.9197

Florida Board of Professional Engineers
 Certificate Of Authorization No. 9813
Ryan J. King 9-8-10
 Ryan J. King, P.E. No. 64619

PRODUCT: WEST TAMPA GLASS SERIES WTG-700

PART OR ASSEMBLY: ANCHORING

NO.	DATE	REVISIONS
2	7/20/10	REVISED PER DADE COMMENTS
1	05/03/10	REVISED PER DADE COMMENTS

DATE: 7/1/09
 SCALE: N.T.S.
 DWG. BY: AL
 CHK. BY: LFS
 DRAWING NO.: S-4089
 SHEET 12 of 18

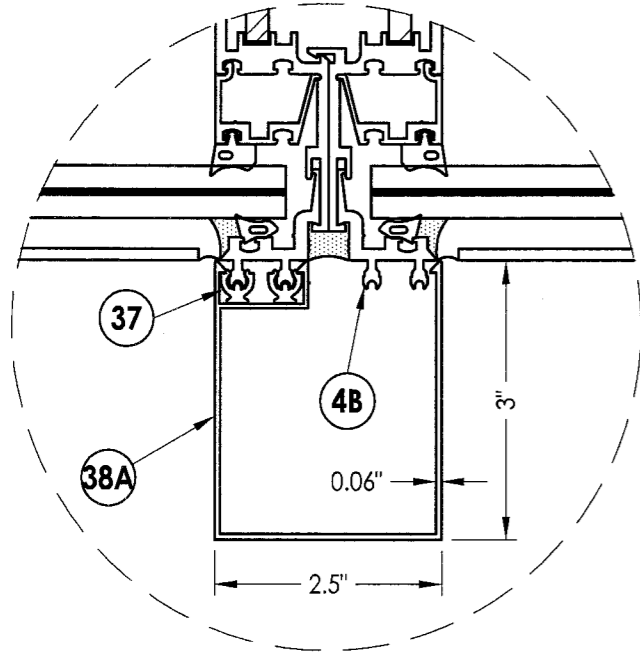

DEEP SQUARE VERTICAL FACE COVER

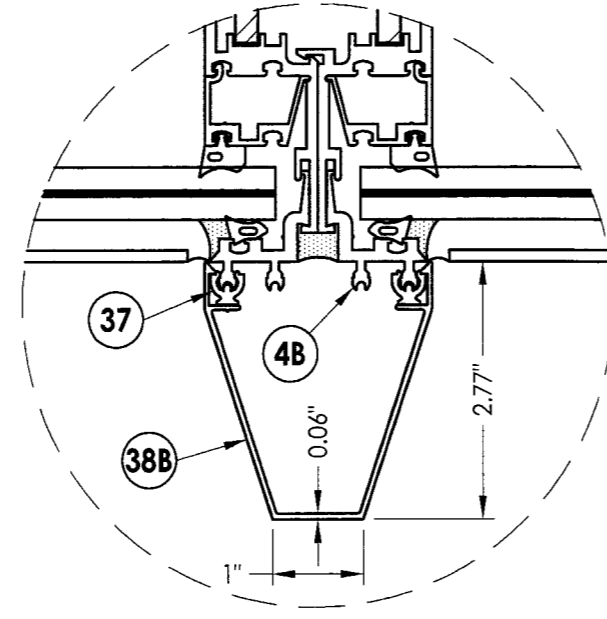

HALF DEEP VERTICAL FACE COVER

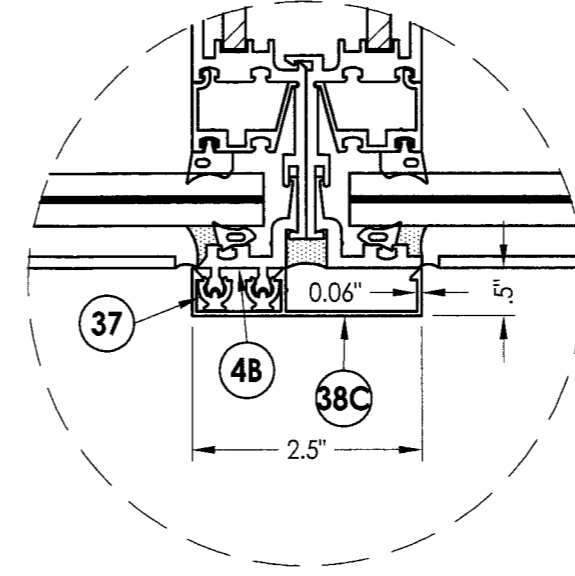

TYPICAL FACE COVER

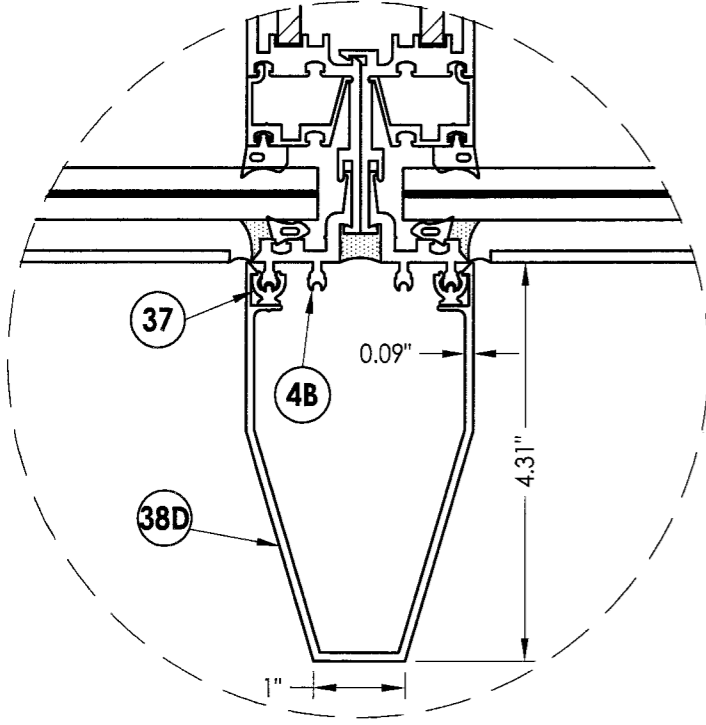

DEEP VERTICAL FACE COVER

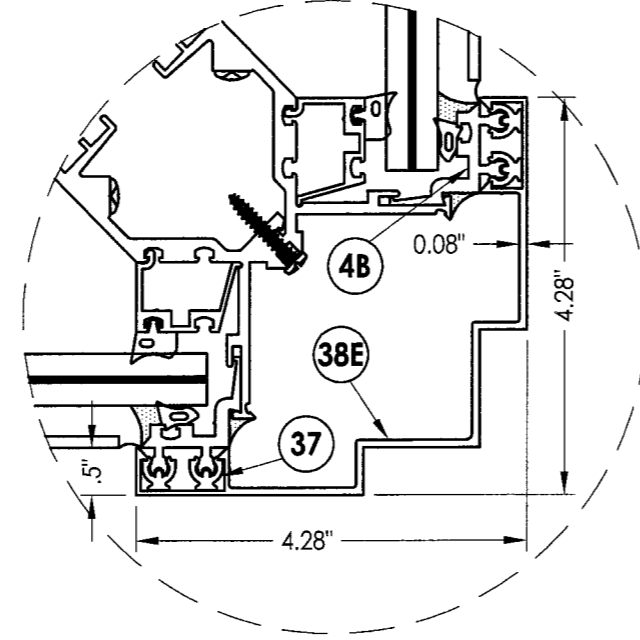

TYPICAL CORNER FACE COVER

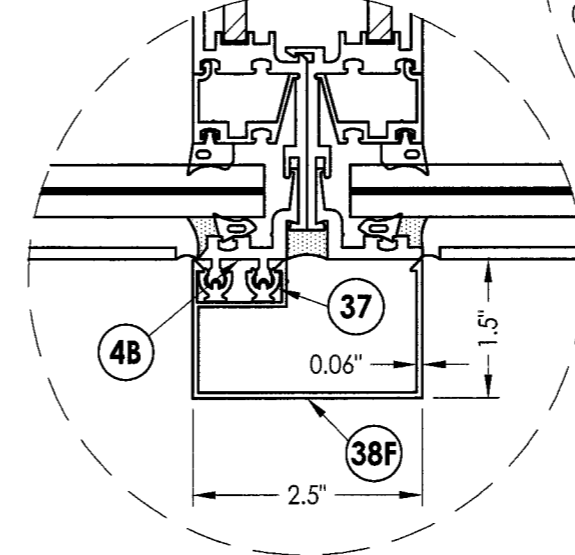

HALF DEEP SQUARE VERTICAL FACE COVER

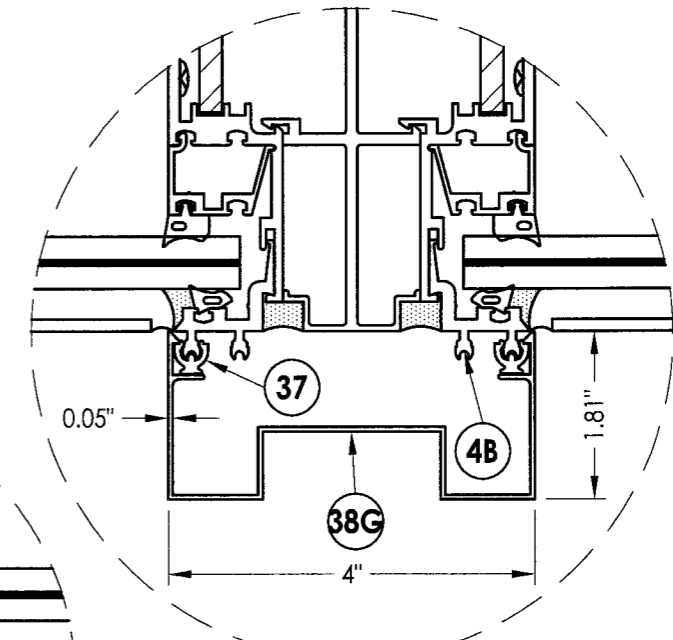

4" NOTCHED VERTICAL FACE COVER

Approved as complying with the Florida Building Code
 Date: 08-19-2010
 NO. 05-1202-D3
 Miami Dade Product Control
 By: *Manuel Cruz*

Documents Prepared By: **RW** BUILDING CONSULTANTS, INC.
 P.O. Box 230 Vairico FL 33595
 Phone No.: 813.659.9197
 Florida Board of Professional Engineers
 Certificate Of Authorization No. 9813
Ryan J. King 9-8-10
 Ryan J. King, P.E. No. 64619

PRODUCT: WEST TAMPA GLASS SERIES WTG-700
 PART OR ASSEMBLY: FACE COVER OPTION DETAILS

NO.	DATE	REVISIONS
2	7/20/10	REVISED PER DADE COMMENTS
1	05/03/10	REVISED PER DADE COMMENTS

DATE: 7/1/09
 SCALE: N.T.S.
 DWG. BY: AL
 CHK. BY: LFS
 DRAWING NO.: S-4089
 SHEET 13 OF 18

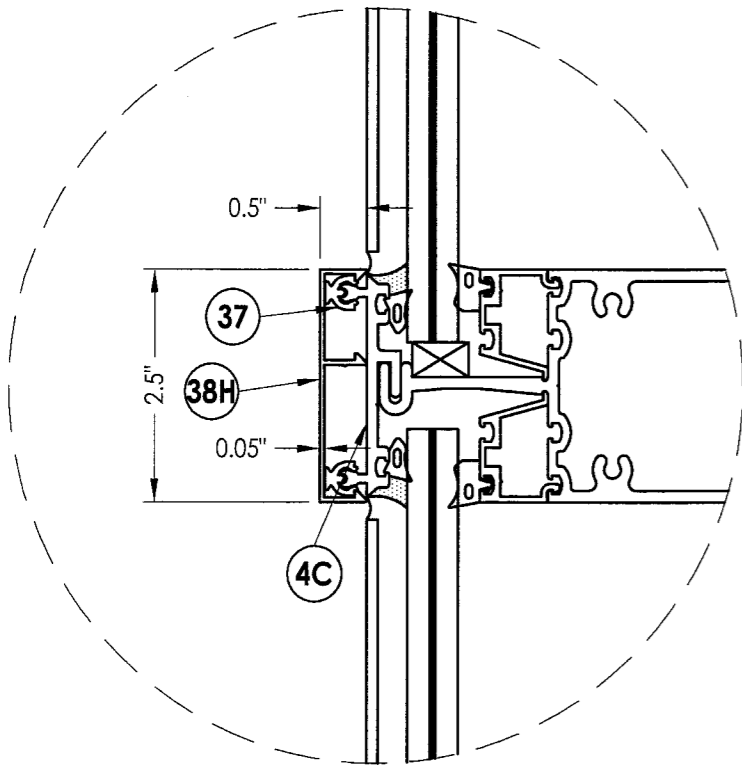

TYPICAL FACE COVER

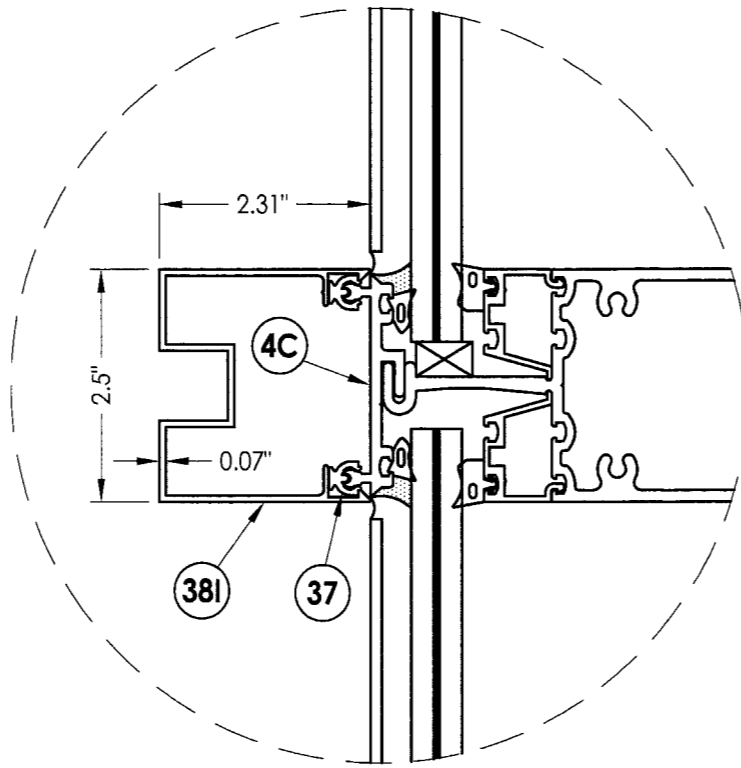

NOTCHED HORIZONTAL FACE COVER

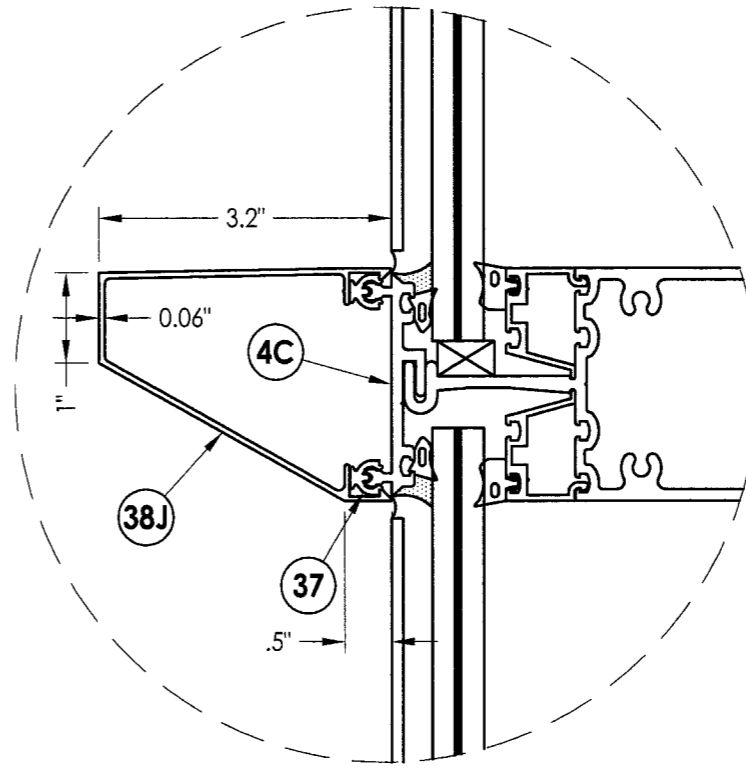

HALF DEEP HORIZONTAL FACE COVER

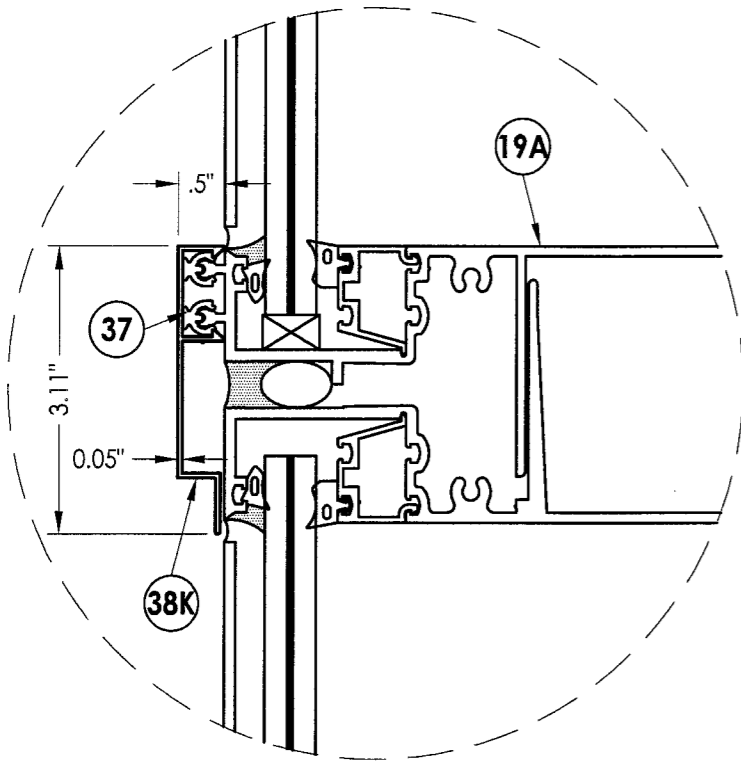

TWIN SPAN HORIZONTAL FACE COVER

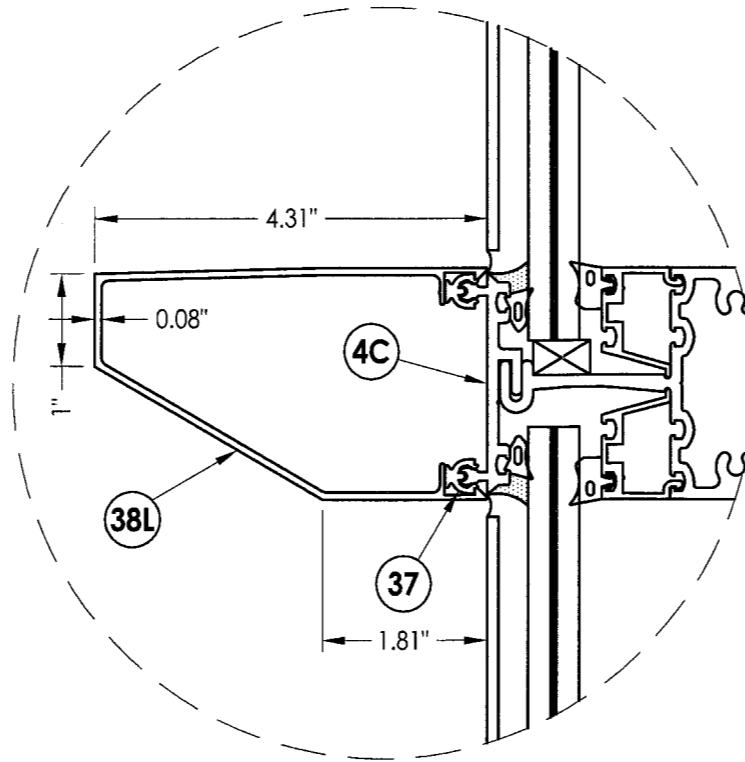

DEEP SLOPED HORIZONTAL FACE COVER

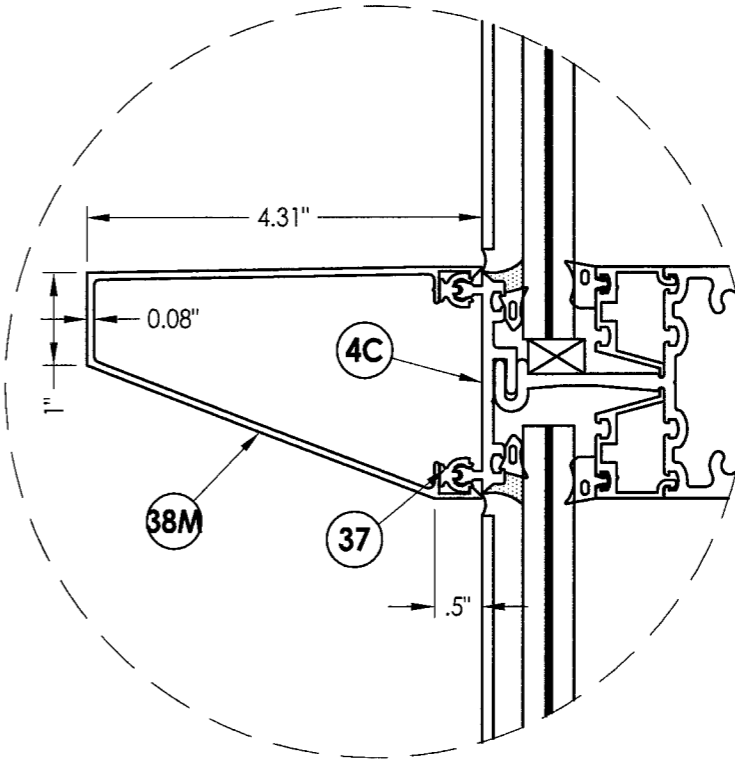

DEEP SLOPED HORIZONTAL FACE COVER OPTION 2

Approved as complying with the Florida Building Code
 Date: 05/11/2010
 NGAP: 05-1202.03
 Miami Best Product Award
 By: *Manuel Silva*

Documents Prepared By:

RW BUILDING CONSULTANTS, INC.
 P.O. Box 230 Valrico FL, 33595
 Phone No.: 813.659.9197
 Florida Board of Professional Engineers
 Certificate Of Authorization No. 9813
Manuel Silva 9-8-10
 Ryan J. King, P.E. No. 64619

PRODUCT: WEST TAMPA GLASS
 SERIES WTG-700

PART OR ASSEMBLY:
 FACE COVER OPTION DETAILS

NO.	DATE	REVISIONS	BY
2	7/20/10	REVISED PER DADE COMMENTS	LFS
1	05/03/10	REVISED PER DADE COMMENTS	JK

DATE: 7/1/09

SCALE: N.T.S.

DWG. BY: AL

CHK. BY: LFS

DRAWING NO.: S-4089

SHEET 14 OF 18

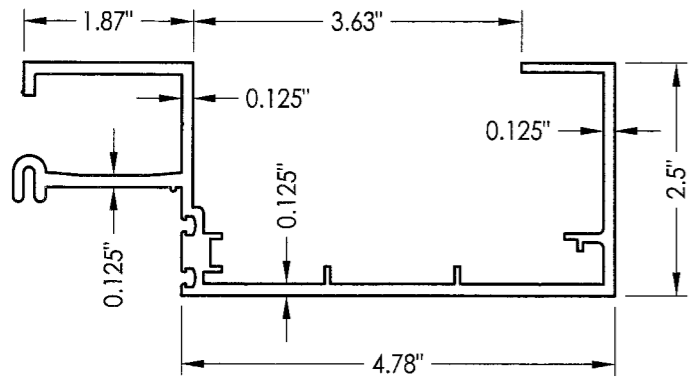

1 JAMB

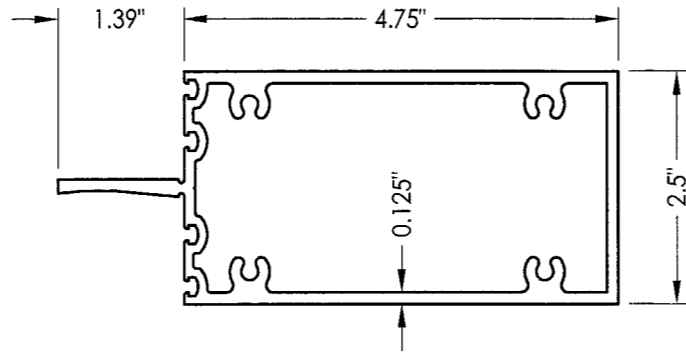

7A INTERMEDIATE HORIZONTAL

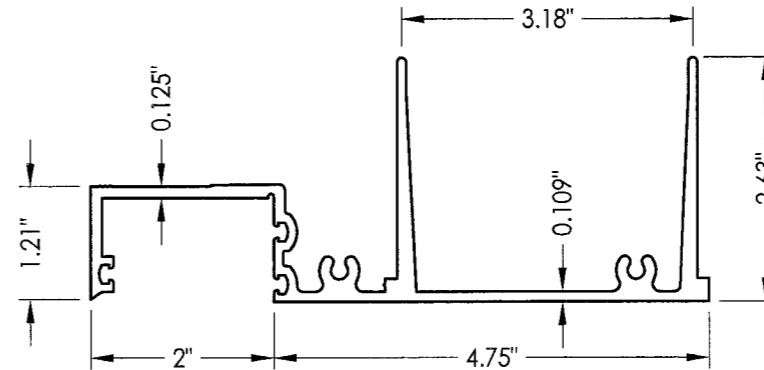

20 BOTTOM TWIN SPAN

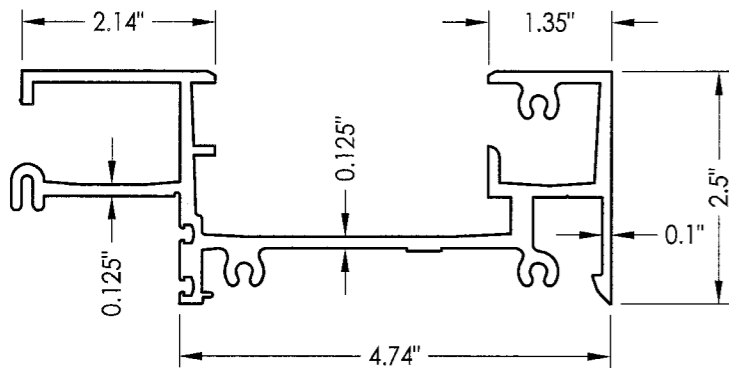

2 HEAD & SILL

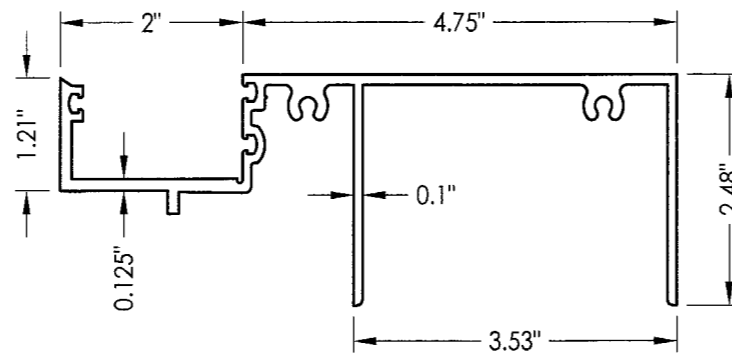

19 TOP TWIN SPAN

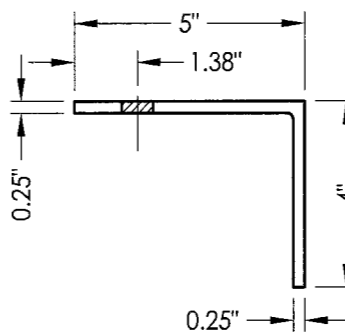
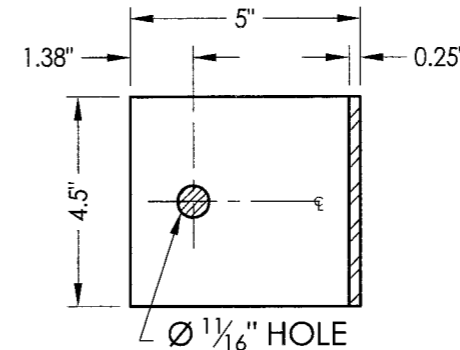

27 DEAD LOAD ANCHOR CLIP

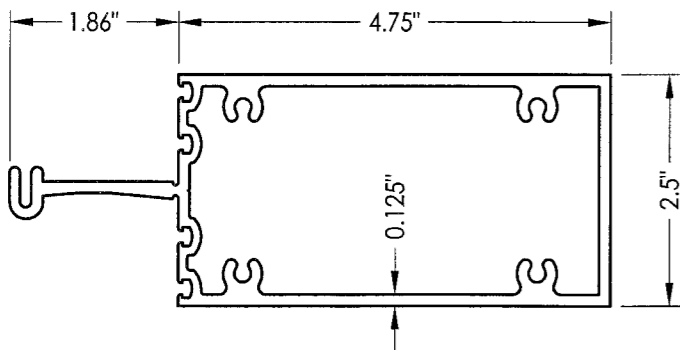

7 INTERMEDIATE HORIZONTAL

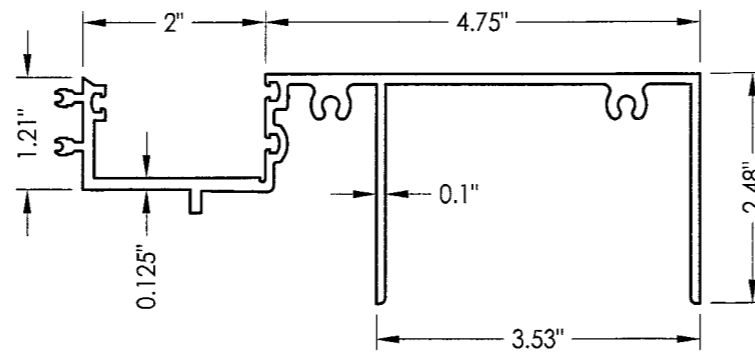

19A TOP TWIN SPAN

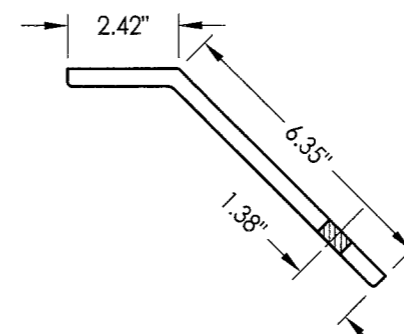

27A DEAD LOAD ANCHOR CLIP @ 45°

Approved as complying with the Florida Building Code
 Date: 08/19/2010
 NO. 081-1202.03
 Miami-Dade Product Control
 By: *Manuel Ruiz*

Documents Prepared By:
RW BUILDING CONSULTANTS, INC.
 P.O. Box 230 Valrico FL 33595
 Phone No.: 813.659.9197
 Florida Board of Professional Engineers
 Certificate of Authorization No. 9813
Manuel Ruiz 9-8-10
 Ryan J. King, P.E. No. 64619

PRODUCT: WEST TAMPA GLASS SERIES WTC-700
 PART OR ASSEMBLY: COMPONENTS

REVISIONS	
NO.	DATE
2	7/20/10
1	05/03/10

DATE: 7/1/09
 SCALE: N.T.S.
 DWG. BY: AL
 CHK. BY: LFS
 DRAWING NO.: S-4089
 SHEET 15 OF 18

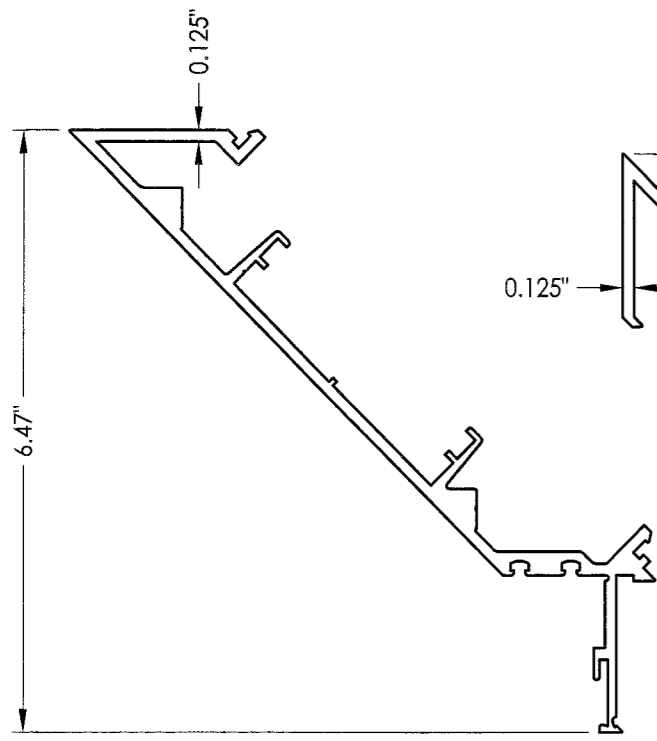

8 MALE CORNER

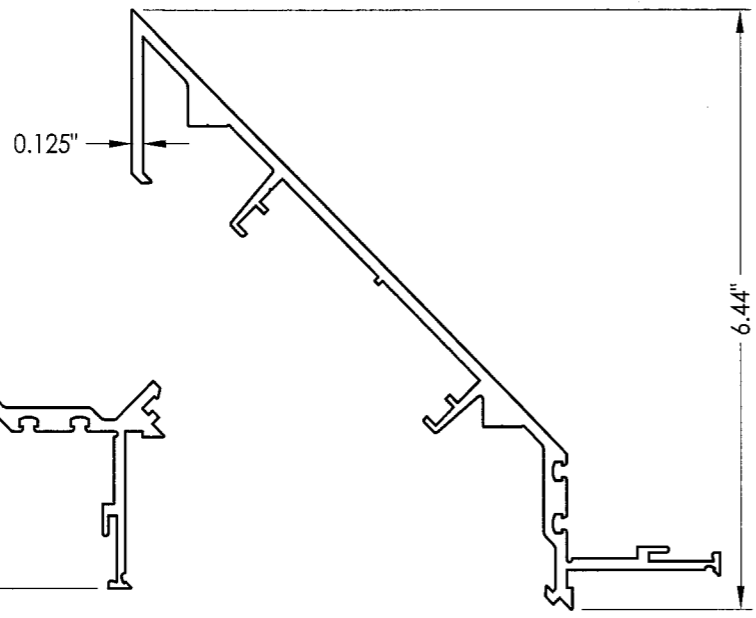

9 FEMALE CORNER

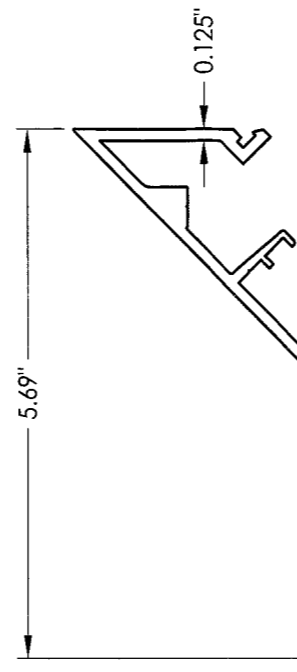

8A MALE CORNER

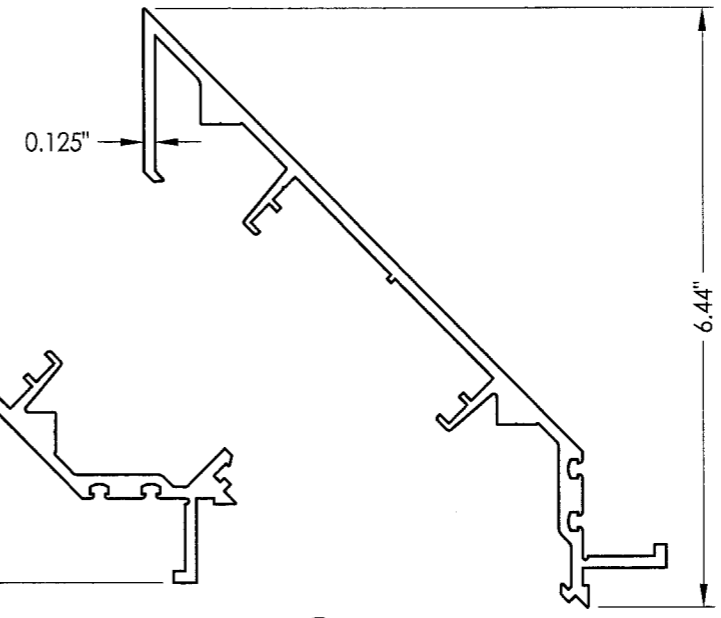

9A FEMALE CORNER

Approved as complying with the Florida Building Code
 Date: 08-9-2010
 NCAP: 08-1202.03
 Miami Trade Product Control
 By: *Manuel Diaz*

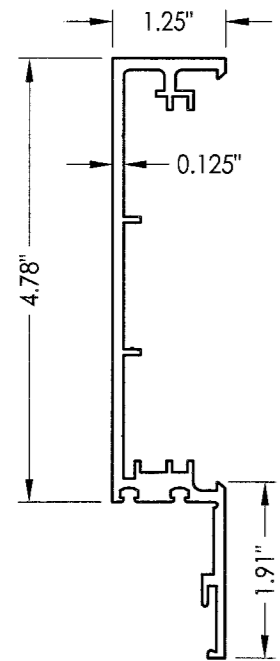

12 MULLION FEMALE

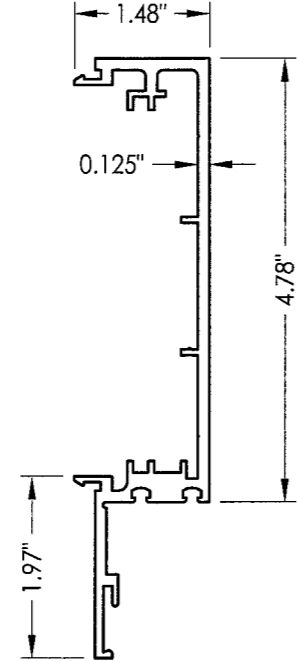

13 MULLION MALE

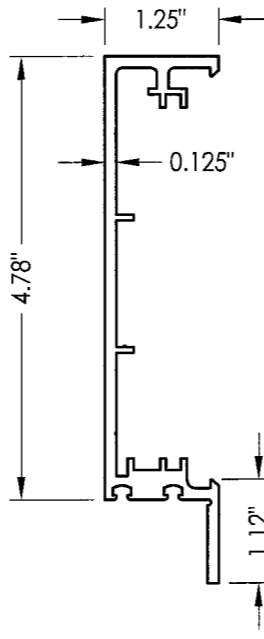

12A MULLION FEMALE



13A MULLION MALE

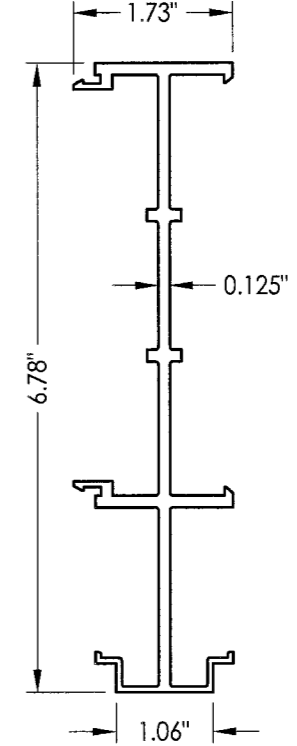

14 MULLION ADAPTOR

PRODUCT:		WEST TAMPA GLASS SERIES WTG-700	
PART OR ASSEMBLY:		COMPONENTS	
NO.	DATE	REVISED PER	COMMENTS
2	7/20/10	REVISOR	LFS
1	05/03/10	REVISOR	JK
REVISIONS			
DATE: 7/1/09			
SCALE: N.T.S.			
DWG. BY: AL			
CHK. BY: LFS			
DRAWING NO.: S-4089			
SHEET 16 OF 18			

Documents Prepared By:
RW
 BUILDING CONSULTANTS, INC.
 P.O. Box 230 Vairico FL 33595
 Phone No.: 813.659.9197
 Florida Board of Professional Engineers
 Certificate Of Authorization No. 9813
Ryan J. King
 Ryan J. King, P.E. No. 64619

BILL OF MATERIALS		
ITEM	DESCRIPTION	MATERIAL
C	MAX. 1/4" SHIM SPACE	-
1	JAMB (#706)	6063-T5 ALUM.
2	HEAD & SILL (#708)	6063-T5 ALUM.
3	HEAD & SILL COVER (#707)	6063-T5 ALUM.
4	GLASS RETAINER (#709)	6063-T5 ALUM.
4A	GLASS RETAINER (#703)	6063-T5 ALUM.
4B	GLASS RETAINER (#703A)	6063-T5 ALUM.
4C	GLASS RETAINER (#709A)	6063-T5 ALUM.
5	GLAZING ADAPTOR (#702)	6063-T5 ALUM.
6	2" X 3" X 1/4" RECTANGULAR TUBE (#710B)	6063-T5 ALUM.
7	INTERMEDIATE HORIZONTAL (#701)	6063-T5 ALUM.
7A	INTERMEDIATE HORIZONTAL (#701A)	6063-T5 ALUM.
8	MALE CORNER (#714)	6061-T6 ALUM.
8A	MALE CORNER (#714A)	6061-T6 ALUM.
9	FEMALE CORNER (#715)	6061-T6 ALUM.
9A	FEMALE CORNER (#715A)	6061-T6 ALUM.
10	ALUMINUM ANGLE CLOSER (1-1/2" X 1-1/2")	6063-T5 ALUM.
11	ANCHOR (SEE ANCHOR SCHEDULE)	STEEL
12	FEMALE MULLION (#705)	6061-T6 ALUM.
12A	FEMALE MULLION (#705A)	6061-T6 ALUM.
13	MALE MULLION (#704)	6061-T6 ALUM.
13A	MALE MULLION (#704A)	6061-T6 ALUM.
14	MULLION ADAPTOR (#725)	6061-T6 ALUM.
15	GLASS POCKET FILLER (#711)	6063-T5 ALUM.
16	ASSEMBLY SCREW #8-18 X 1" PH SMS	STEEL
16A	ASSEMBLY SCREW #12-18 X 1-1/2" PH SMS	STEEL
17	ALUM. CLOSER .060 ALUM. BREAKMETAL	6063-T5 ALUM.
18	ALUM. CORNER .060 ALUM. BREAKMETAL	6063-T5 ALUM.
19	TOP TWIN SPAN (#712)	6063-T5 ALUM.
19A	TOP TWIN SPAN (#712A)	6063-T5 ALUM.
20	BOTTOM TWIN SPAN (#713)	6063-T5 ALUM.
21	SPLICE 4" X 6-1/2" X 1/4"	6061-T6 ALUM.
22	SPACER GASKET INTERIOR (GK004) TREMCO SCR-900 70 DUROMETER	EPDM
24	WEDGE GASKET EXTERIOR (GK005) TREMCO SCR-900 70 DUROMETER	EPDM
25	SEALANT DOW 995 OR DOW 983	SILICONE
26	SETTING BLOCK 3/8" X 5/8" X 4" FOR 9/16" GLASS	EPDM / SILICONE
26A	SETTING BLOCK 3/8" X 1-1/4" X 4" FOR 1-5/16" GLASS	EPDM / SILICONE
26B	CLOSER BLOCK 1-3/4" X 1" CLOSED CELL FOAM	FOAM
27	DEAD LOAD ANCHOR CLIP 4" X 5" X 4-1/2" X 1/4"	STEEL
27A	DEAD LOAD ANCHOR CLIP 6-1/4" X 4-1/2" X 1/4" @ 45°	STEEL
28	SETTING BLOCK 1/8" X 1-1/4" X 4" FOR 1-5/16" HORIZONTAL BUTT GLASS	EPDM / SILICONE
28A	SETTING BLOCK 1/8" X 5/8" X 4" FOR 9/16" HORIZONTAL BUTT GLASS	EPDM / SILICONE
29	NYLON SLIP PAD 3-1/2" X 4-1/2" X .625"	NYLON
30	BACKER ROD CLOSED CELL EXTRUDED FOAM	FOAM
31	SEALANT DOW 983 OR DOW 795	SILICONE

BILL OF MATERIALS		
ITEM	DESCRIPTION	MATERIAL
31A	SEALANT DOW 795	SILICONE
32	5/8"-11 X 4-1/2" GR5 BOLT W/ NUT & LOCK WASHER	STEEL
32A	5/8"-11 X 2.5" GR5 BOLT W/ NUT & LOCK WASHER	STEEL
33	GLAZING SPACER AT INSULATED GLASS	ALUM. OR S.S.
34	5/16"-18 X 3/4" HH GR5 BOLT	STEEL
35	1/4" X 3" ST. HOT ROLLED FLAT BAR PRIMER FINISH (ASTM A588)	STEEL
36	1/4" X 4" ST. HOT ROLLED FLAT BAR PRIMER FINISH (ASTM A588)	STEEL
36A	1/8" X 4" ST. HOT ROLLED FLAT BAR PRIMER FINISH (ASTM A588)	STEEL
36B	1/2" X 3-1/2" ST. HOT ROLLED FLAT BAR PRIMER FINISH @ DOOR JAMB (ASTM A588)	STEEL
37	PLASTIC CLIPS	PLASTIC
38A	FACE COVER	6063-T5 ALUM.
38B	FACE COVER	6063-T5 ALUM.
38C	FACE COVER	6063-T5 ALUM.
38D	FACE COVER	6063-T5 ALUM.
38E	FACE COVER	6063-T5 ALUM.
38F	FACE COVER	6063-T5 ALUM.
38G	FACE COVER	6063-T5 ALUM.
38H	FACE COVER	6063-T5 ALUM.
38I	FACE COVER	6063-T5 ALUM.
38J	FACE COVER	6063-T5 ALUM.
38K	FACE COVER	6063-T5 ALUM.
38L	FACE COVER	6063-T5 ALUM.
38M	FACE COVER	6063-T5 ALUM.
41	1/8" X 2" X 11-3/4" STEEL ANGLE CLIP W/ ZINCROMATE PAINTED	STEEL

Approved as complying with the Florida Building Code
 Date: 05/11/09
 NCAP 05-1202-03
 Miami Dade Product Control
 By: *Manuel Perez*

Documents Prepared By: **RW** BUILDING CONSULTANTS, INC.
 P.O. Box 230 Valrico FL 33595
 Phone No.: 813.659.9197
 Florida Board of Professional Engineers
 Certificate Of Authorization No. 9813
Manuel Perez 9-8-10
 Ryan J. King, P.E. No. 64619

PRODUCT: WEST TAMPA GLASS SERIES WTG-700
 PART OR ASSEMBLY: BILL OF MATERIALS

NO.	DATE	REVISIONS
2	7/20/10	REVISED PER DADE COMMENTS
1	05/03/10	REVISED PER DADE COMMENTS

DATE: 7/1/09
 SCALE: N.T.S.
 DWG. BY: AL
 CHK. BY: LFS
 DRAWING NO.: S-4089
 SHEET 18 OF 18

© 2009 R.W. BUILDING CONSULTANTS INC.